



EN

DECLARATION OF PERFORMANCE

according to the construction products (Amendment etc.) (EU Exit) Regulation 2020

Hilti powder-actuated fastener X-U16 S12
No. Hilti-DX-DoP-403

1. Unique identification code of the product-type:

Hilti powder-actuated fastener X-U16 S12 in combination with Hilti powder-actuated fastening tool DX 462

2. Type, batch or serial number or any other element allowing identification of the construction: Type and lot number are displayed on the packaging

3. Intended use or uses of the construction product, in accordance with the applicable harmonized technical specification, as foreseen by the manufacturer:

Intended use	
Base material	Structural steel S235, S275 and S355 in qualities JR, JO, J2, K2 according to EN 10025-2.
Loading	Static and quasi-static loads in building construction.

4.1 Name, registered trade name or registered trade mark and contact address of the manufacturer:

Hilti Aktiengesellschaft, Business Unit Direct Fastening, 9494 Schaan, Fürstentum Liechtenstein

4.2 Name of the UK importer:

Hilti (Gt. Britain) Limited, No. 1 Circle Square, 3 Symphony Park, Manchester, England, M1 7FS

5. Where applicable, name and contact address of the authorised representative whose mandate covers the tasks:
n.a.

6. System or systems of assessment and verification of constancy of performance of the construction product:
System 2+

7. In case of the declaration of performance concerning a construction product covered by a harmonised standard:
n.a.

8. In case of the declaration of performance concerning a construction product for which a UK Technical Assessment has been issued:

BBA, British Board of Agreements issued UKTA-0836-22/6557 on the basis of UKAD 330153-00-0602. The notified body BBA performed third party tasks under system 2+ and issued the certificate of conformity of the factory production control UK 0836-CPR-23/F6994.

9. Declared performance:

Essential characteristics	Performance
Characteristic shear resistance V_{Rk} and tension resistance N_{Rk}	See Annex C1 of UKTA-0836-22/6557
Types of connection	See Annex B2 of UKTA-0836-22/6557
Application limit	See Annex B3 of UKTA-0836-22/6557
Resistance to fire	See Annex C1 of UKTA-0836-22/6557

The relevant annexes from UKTA-0836-22/6557 as referenced above are summarized below:



Annex C1 of UKTA-0836-22/6557

Table 4: Characteristic shear resistance V_{Rk} and tension resistance N_{Rk}

sheeting thickness t_i [mm]	Shear V_{Rk} [kN]	Tension N_{Rk} [kN]	Types of connection
0.75	2.4	2.8	a
1.00	3.6	3.6	a
1.25	5.2	4.4	a
1.50	5.2	4.4	a

Table 5: Design shear resistance V_{Rd} and tension resistance N_{Rd}

$V_{Rd} = V_{Rk} / \gamma_M$	$N_{Rd} = \alpha_{cycl} N_{Rk} / \gamma_M$ $\alpha_{cycl} = 1.0$
$\gamma_M = 1.25$ in the absence of national regulations	α_{cycl} considers the effect of repeated wind loads $\alpha_{cycl} = 1.0$ for all sheeting thickness t_i $\gamma_M = 1.25$ in the absence of national regulations

Annex B2 of UKTA-0836-22/6557

Table 3: Type of connection and corresponding loading conditions

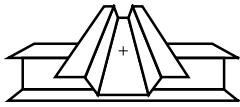
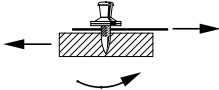
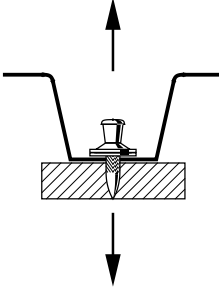
	Type of connection
	Type a
	
Type of loading	Single connection
Shear loading	
Tension loading	

Annex B3 of UKTA-0836-22/6557

Application limit diagram:	Tool energy setting:
	<p>The powder-actuated fasteners are to be driven flush.</p> <p>After installation the nail head standoff h_{NVS} has to meet the values given in Annex C1. The driving energy is adjusted at the fastening tool by means of trial installations.</p> <p>1 ... for thin low strength base material</p> <p>4 ... along the upper application limit curve</p>

Powder-actuated fastening tool DX 462 with 12 mm fastener guide and cartridge 6.8/11M

<p>Piston: X-462-P8, Fastener Guide: X-462-F8S12</p>	<p>Black: Extra high load (level 7) S235 – S355: Black</p>
<p>Wheel on tool allowing regulation of the driving energy:</p> <p>Setting 1: Minimum energy Setting 4: Maximum energy</p>	

Annex C1 of UKTA-0836-22/6557

Fastener inspection – nail head standoff h_{NVS}

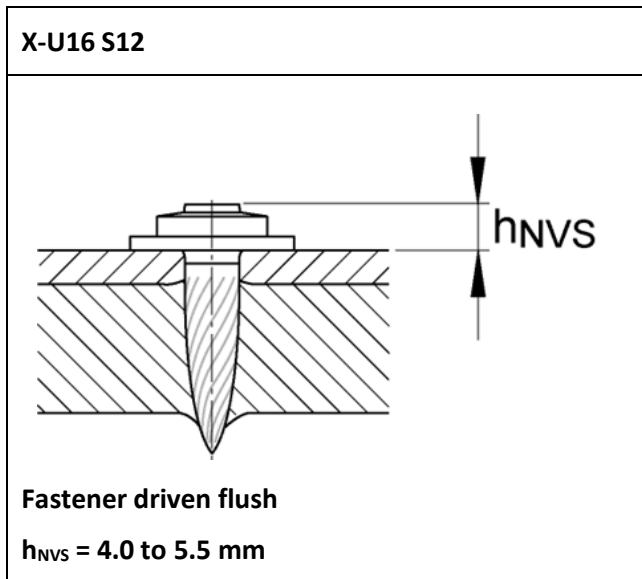

Resistance to fire

The part of the structure in which the powder-actuated fasteners X-U16 S12 are intended to be installed shall be tested, using the test method relevant for the corresponding fire resistance class, in order to be classified according to the appropriate part of EN 13501.

10. The performance of the product identified in points 1 and 2 is in conformity with the declared performance in point 9. This declaration of performance is issued under the sole responsibility of the manufacturer identified in point 4.

Signed for and on behalf of the manufacturer by:

Klaus Bertsch

Head of Quality Direct Fastening

Hilti Aktiengesellschaft, Schaan: 01.09.2023