



Designated according to The Construction Products (Amendment etc.) (EU Exit) Regulations 2020

UK Technical Assessment		UKTA-0836-21/0007 of 16/12/2021	
Technical Assessment Body issuing the UK Technical Assessment:		British Board of Agrément	
Trade name of the construction product:		HCX-R Cast-in socket	
Product family to which the construction product belongs:		Cast-in anchor with an internal threaded socket	
Manufacturer:		HILTI Corporation Feldkircherstrasse 100 9494 SCHAAN Principality of Liechtenstein	
Manufacturing plant(s):		Hilti Plants	
This UK Technical Assessment contains:		15 pages including 10 annexes which form an integral part of this assessment.	
This UK Technical Assessment is issued in accordance with The Construction Products (Amendment etc.) (EU Exit) Regulations 2020 on the basis of:		UKAD No. 330012-00-0601: "Cast-in anchor with internal threaded socket"	

Communication of this UK Technical Assessment, including transmission by electronic means, shall be in full. However, partial reproduction may be made with the written consent of the British Board of Agrément. Any partial reproduction must be identified as such.

1 Technical description of the product

HCX-R Cast-in socket in size M16 is an anchor consisting of an internal threaded socket with a round pin. The socket is made of stainless steel.

The anchor is embedded surface–flush. The anchorage is established by the engagement of a rounded pin which is positioned perpendicular to the socket.

An illustration of the product is given in Annex A1.

2 Specification of the intended use(s) in accordance with the applicable UK Assessment Document (hereinafter UKAD)

The performances given in Annex 3 are only valid if the anchor is used in compliance with the specifications and conditions given in Annex B.

The provisions made in this UK Technical Assessment are based on an assumed working life of the anchor of 50 years. The indications given on the working life cannot be interpreted as a guarantee given by the manufacturer but are to be regarded only as a means for choosing the right products in relation to the expected economically reasonable working life of the works.

3 Performance of the product and references to the methods used for its assessment

3.1 Mechanical resistance and stability (BWR 1)

The basic work requirements for mechanical resistance and stability are listed in Annexes C1 to C3.

3.2 Safety in case of fire (BWR 2)

The basic work requirements for safety in case of fire are listed in Annexes C4 and C5.

3.3 Health, hygiene and the environment (BWR 3)

Not relevant

3.4 Safety and accessibility in use (BWR 4)

Not relevant

3.5 Protection against noise (BWR 5)

Not relevant

3.6 Energy economy and heat retention (BWR 6)

Not relevant

3.7 Sustainable use of natural resources (BWR 7)

No Performance assessed

3.8 General aspects relating to fitness for use

Durability and serviceability are only ensured if specifications of intended use according to Annex B1 are kept.

4 Assessment and verification of constancy of performance (hereinafter AVCP) system applied

4.1 System of assessment and verification of constancy of performance

According to UKAD No. 330012-00-0601 and Annex V of the Construction Products Regulation (Regulation (EU) 305/2011 as brought into UK law and amended, the system of assessment and verification of constancy of performance (AVCP) 1 applies.

5 Technical details necessary for the implementation of the AVCP system, as provided for in the applicable UKAD

Technical details necessary for the implementation of the AVCP system are laid down in the control plan deposited with the British Board of Agrément and made available to the UK Approved Bodies involved in the conformity attestation process.

5.1 UKCA marking for the product/ system must contain the following information:

- Identification number of the Approved Body
- Name/address of the manufacturer of the product/ system
- Marking with intention of clarification of intended use
- Date of marking
- Number of certificate of constancy of performance
- UKTA number.

On behalf of the British Board of Agrément



Date of Issue: 16 December 2021

Hardy Giesler
Chief Executive



British Board of Agrément,
Bucknalls Lane,
Watford,
Hertfordshire
WD25 9BA

Installed condition

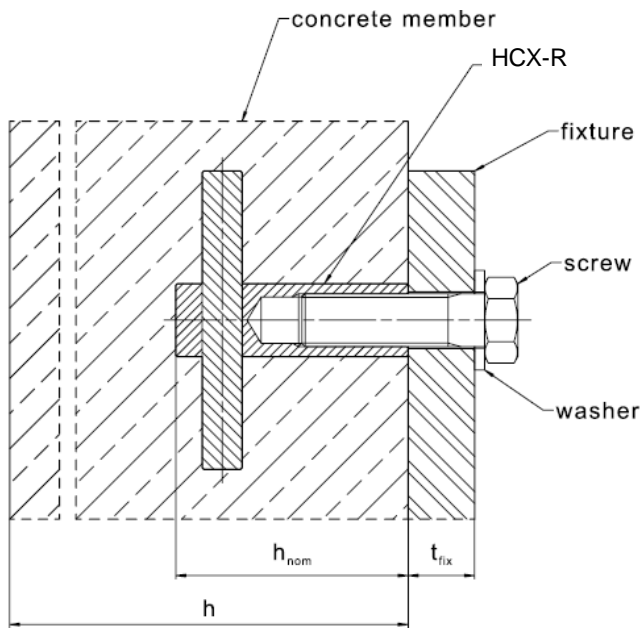

- h = thickness of concrete member
- t_{fix} = thickness of the fixture
- h_{nom} = nominal embedment depth

Product description

Hilti cast-in socket anchor HCX-R

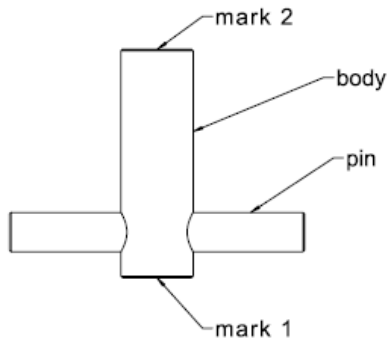

Anchor Marking

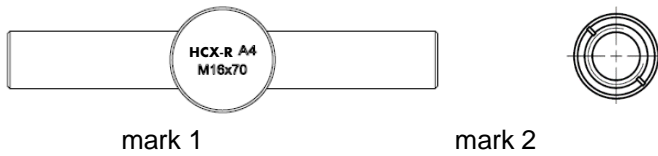

<p>HCX-R Cast-in socket</p>
<p>Product description Installed condition and marking</p>

Annex A1

Table A1: Material for socket

Designation	Material
HCX-R M16	
Anchor body	Stainless Steel A4, $f_{uk} \geq 580 \text{ N/mm}^2$, $f_{yk} \geq 420 \text{ N/mm}^2$
Anchor pin	Stainless Steel A4, $f_{uk} \geq 580 \text{ N/mm}^2$, $f_{yk} \geq 420 \text{ N/mm}^2$

Table A2: Material for screw (not included with the fixing system)

Designation	Material
M16	
Screw	Stainless Steel A4 – 70 according to BS EN ISO 898-1

HCX-R Cast-in socket	Annex A2
Product description Material	

Specifications of intended use

Anchorage subjected to:

- Static and quasi static loading.
- Fire exposure: only for concrete C20/25 to C50/60.

Base materials:

- Reinforced or unreinforced normal weight concrete according to EN 206:2013+A1:2016.
- Strength classes C20/25 to C90/105 according to EN 206:2013+A1:2016. However, in the calculation of resistance the values of f_{ck} shall not exceed 50 N/mm², even when the product is casted-in concrete of higher concrete strength.
- Cracked and uncracked concrete.

Use conditions (Environmental conditions):

- Anchorages subject to dry internal conditions and also in structures subject to external atmospheric exposure (including industrial and marine environments), or exposure in permanently damp internal conditions, if no particular aggressive conditions exist.
Note: Particularly aggressive conditions are permanent alternating immersion in seawater or the splash zone of seawater, chloride atmosphere of indoor swimming pools or atmosphere with extreme chemical pollution (e.g. desulfurization plants or road tunnels, where de-icing materials are used).

Design:

- Anchorages are designed under the responsibility of an engineer experienced in anchorages and concrete work.
- Verifiable calculation notes and drawings are prepared taking account of the loads to be anchored. The position of the anchor is indicated on the design drawings (e.g. position of the anchor relative to reinforcement or to supports etc.).
- Anchorages under static or quasi-static loading are designed in accordance with CEN/TS 1992-4, part 1 and 2.
- Anchorages under fire exposure are designed in accordance with EOTA TR 020, Edition May 2004.
- The screw is chosen with corresponding screw-in length according to Annex B2, Table B1 and with the strength class according to Annex C1 and C2 subject to the required steel resistance with the material according to Annex A2, Table A2.

Installation:

- Anchor installation carried out by appropriately qualified personnel and under the supervision of the person responsible for technical matters of the site.
- The anchors are fixed on the formwork so that no movement of the anchors will occur during the time of laying the reinforcement and of placing and compacting the concrete.
- Adequate compaction close to the anchor particularly at the head of the bolt, e.g. without significant voids. The cast-in anchor is protected against ingress of concrete into the threaded socket. The inner area of the socket made of stainless steel is to be protected against oil. The setting torque given in Annex B2 is not exceeded.
- The anchor may only be set once.
- Overhead applications are permitted.

HCX-R Cast-in socket	Annex B1
Intended use Specifications	

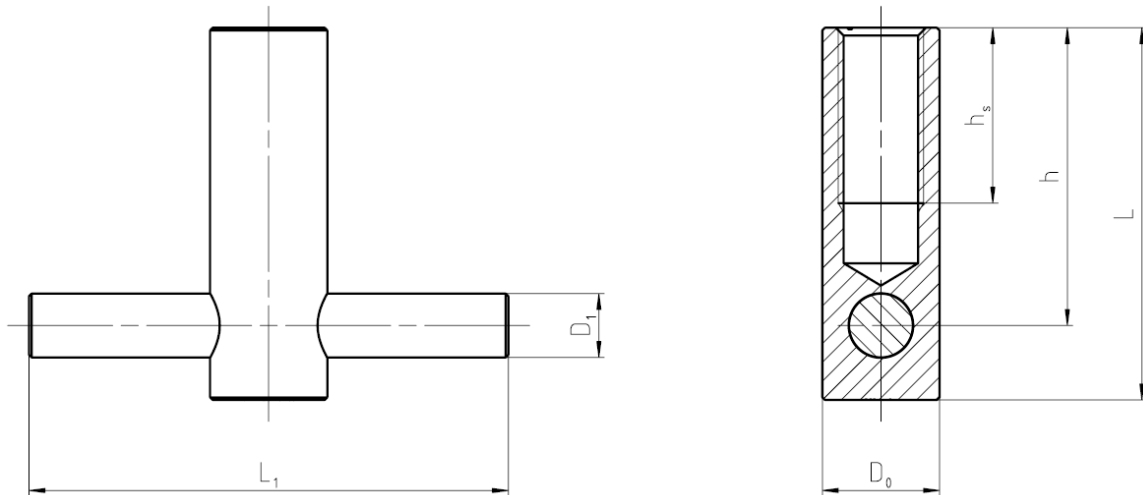

Table A2: Fastener dimensions

HCX-R			M16
Anchor body diameter	D_0	[mm]	22
Anchor length	L	[mm]	70
Anchor pin diameter	D_1	[mm]	12
Anchor pin position from top	h	[mm]	56
Allowable screwing depth	$h_{s,min}$	[mm]	19
	$h_{s,max}$	[mm]	33
Anchor pin length	L_1	[mm]	90

HCX-R			M16
Nominal embedment depth	h_{nom}	[mm]	70
Effective embedment depth	h_{ef}	[mm]	50
Max. diameter of clearance hole in the fixture	d_f	[mm]	18
Min. thickness of concrete member	h_{min}	[mm]	100
Maximum setting torque	$\max T_{inst}$	[Nm]	≤ 50
Minimum edge distance and spacing	S_{min}	[mm]	150
	C_{min}	[mm]	100

HCX-R Cast-in socket	Annex B2
Intended use Fastener dimensions and installation parameters	

Installation instruction

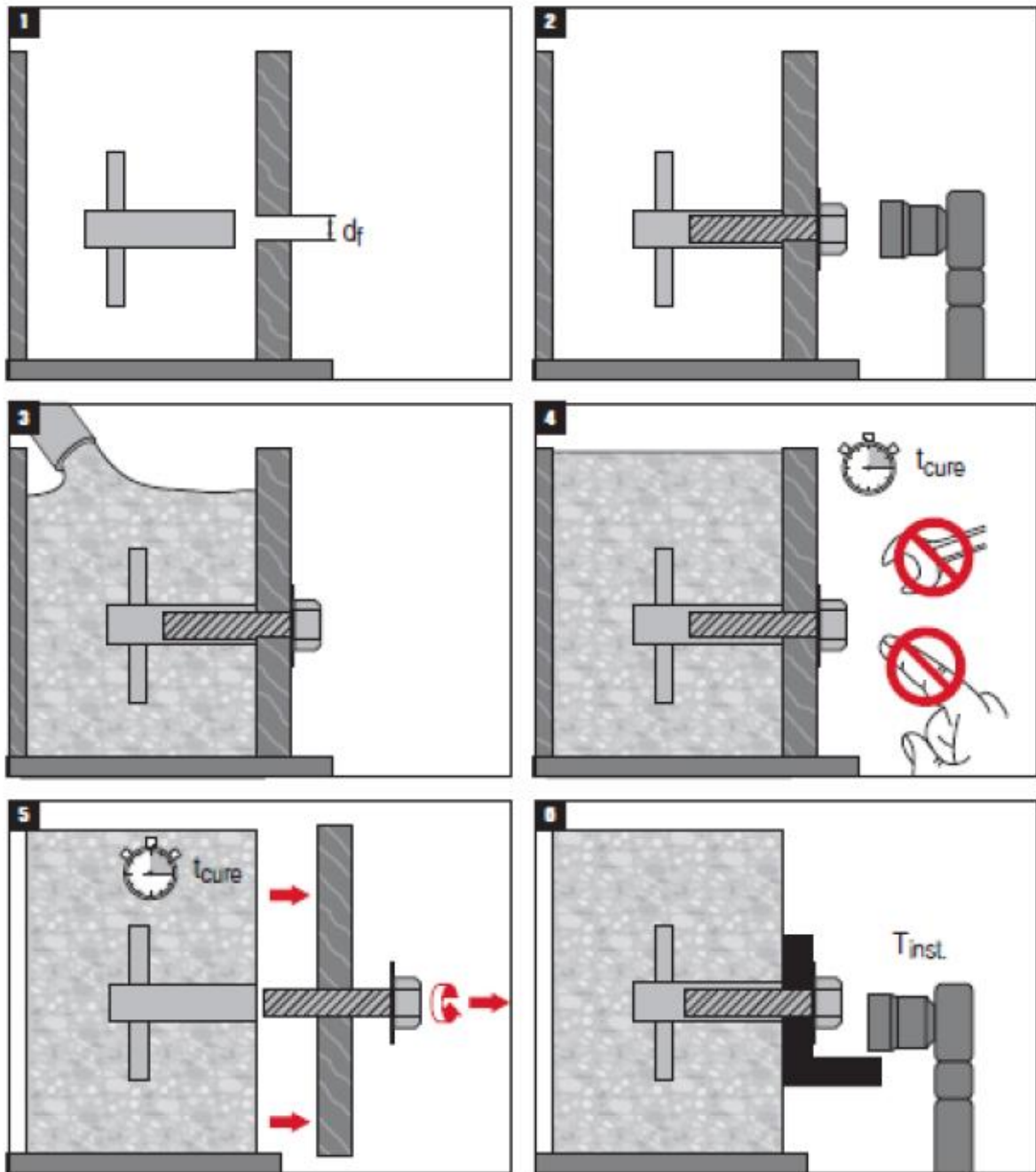

HCX-R Cast-in socket

Intended use
Installation instruction

Annex B3

Table C1: Characteristic resistance under tension load of static and quasi-static loading

Size			HCX-R M16
Effective embedment depth	h_{ef}	[mm]	50
Steel failure , fixing anchor and screw (min. steel strength A4-70) made of stainless steel			
Partial safety factor	$\gamma_{Ms}^{1)}$	[-]	1,66
Characteristic resistance	$N_{Rk,s}$	[kN]	66,1
Pull-out failure			
Characteristic resistance in concrete C20/25			
Installation safety factor	γ_{inst}	[-]	1,0
Uncracked concrete	$N_{Rk,p,ucr}$	[kN]	- ²⁾
Cracked concrete	$N_{Rk,p,cr}$	[kN]	- ²⁾
Increasing factor ψ_c	C30/37	[-]	1,22
	C40/50	[-]	1,41
	C50/60	[-]	1,55
Concrete cone and splitting failure			
Installation safety factor	γ_{inst}	[-]	1,0
Factor for uncracked concrete	k_{ucr}	[-]	11,9
Factor for cracked concrete	k_{cr}	[-]	8,5
Spacing	$S_{cr,N}$	[mm]	$3 \cdot h_{ef}$
Edge distance	$C_{cr,N}$	[mm]	$1,5 \cdot h_{ef}$
Spacing (splitting)	$S_{cr,sp}$	[mm]	150
Edge distance (splitting)	$C_{cr,sp}$	[mm]	75

¹⁾ In absence of other national regulations

²⁾ Pull-out failure is not decisive

HCX-R Cast-in socket

Performances

Essential characteristic for HCX-R Cast-in socket under tension loads

Annex C1

Table C2: Characteristic resistance under shear load of static and quasi-static loading

Size			HCX-R M16
Effective embedment depth	h_{ef}	[mm]	50
Steel failure without lever arm			
Steel failure , fixing anchor and screw (min. steel strength A4-70) made of stainless steel			
Partial safety factor	$\gamma_{Ms}^{1)}$	[-]	1,56
Ductility factor	k_7	[-]	1,0
Characteristic resistance	$V_{Rk,s}$	[kN]	55,0
Steel failure with lever arm			
Steel failure , fixing anchor and screw (min. steel strength A4-70) made of stainless steel			
Partial safety factor	$\gamma_{Ms}^{1)}$	[-]	1,56
Ductility factor	k_7	[-]	1,0
Characteristic resistance	$M^0_{Rk,s}$	[kN]	233,2
Concrete pry-out failure			
Pry-out factor	k_8	[-]	1,0
Installation safety factor	γ_{inst}	[-]	1,0
Concrete edge failure			
Effective length of fastener under shear loading	$l_f = h_{ef}$	[mm]	50
Outside diameter of fastener	d_{nom}	[mm]	22
Installation safety factor	γ_{inst}	[-]	1,0

¹⁾ In absence of other national regulations

HCX-R Cast-in socket

Performances

Essential characteristic for HCX-R Cast-in socket under shear loads

Annex C2

Table C2: Displacement under tension load in case of static and quasi-static loading

Size		HCX-R M16	
Effective embedment depth	h_{ef}	[mm]	50
Tension load in uncracked concrete C20/25	N	[kN]	10,0
Displacement	δ_{N0}	[mm]	0,03
	$\delta_{N\infty}$	[mm]	0,06
Tension load in uncracked concrete C50/60	N	[kN]	15,5
Displacement	δ_{N0}	[mm]	0,05
	$\delta_{N\infty}$	[mm]	0,10
Tension load in cracked concrete C20/25	N	[kN]	7,2
Displacement	δ_{N0}	[mm]	0,05
	$\delta_{N\infty}$	[mm]	0,10
Tension load in cracked concrete C50/60	N	[kN]	11,1
Displacement	δ_{N0}	[mm]	0,09
	$\delta_{N\infty}$	[mm]	0,18

Table C4: Displacement under shear load in case of static and quasi-static loading

Size		HCX-R M16	
Effective embedment depth	h_{ef}	[mm]	50
Shear load in uncracked concrete C20/25 to C50/60	V	[kN]	25,1
Displacement	δ_{V0}	[mm]	1,16
	$\delta_{V\infty}$	[mm]	1,75

HCX-R Cast-in socket

Performances
Displacements under static or quasi-static loading

Annex C3

Table C5: Characteristic resistance to tension load in cracked and uncracked concrete under fire exposure¹⁾

Size		HCX-R M16	
Effective embedment depth	h_{ef}	[mm]	50
Steel failure			
Characteristic resistance	$N_{Rk,s,fi(30)}$	[kN]	4,71
	$N_{Rk,s,fi(60)}$	[kN]	3,93
	$N_{Rk,s,fi(90)}$	[kN]	3,14
	$N_{Rk,s,fi(120)}$	[kN]	2,51
Pull-out failure			
Characteristic resistance $\geq C20/25$	$N_{Rk,p,fi(30)}$	[kN]	- ³⁾
	$N_{Rk,p,fi(60)}$	[kN]	- ³⁾
	$N_{Rk,ps,fi(90)}$	[kN]	- ³⁾
	$N_{Rk,p,fi(120)}$	[kN]	- ³⁾
Concrete cone and splitting failure³⁾			
Characteristic resistance $\geq C20/25$	$N_{Rk,c,fi(30)}$	[kN]	3,76
	$N_{Rk,c,fi(60)}$	[kN]	3,76
	$N_{Rk,c,fi(90)}$	[kN]	3,76
	$N_{Rk,c,fi(120)}$	[kN]	3,01
Characteristic spacing	$S_{cr,N,fi}$	[mm]	$2 \cdot C_{cr,N,fi}$
Characteristic edge distance	$C_{cr,N,fi}$	[mm]	$2 \cdot h_{ef}$

¹⁾ Design under fire exposure is performed according to the design method given in EOTA TR 020. Under fire exposure usually cracked concrete is assumed. The design equations are given in EOTA TR 020, Section 2.2.1.

²⁾ As a rule, splitting failure can be neglected when cracked concrete and reinforcement is assumed.

³⁾ Pull-out failure is not decisive.

EOTA TR 020 covers design for fire exposure from one side. For fire attack from more than one side the edge distance must be increased to $c_{min} \geq 300$ mm and $\geq 2 \cdot h_{ef}$.

HCX-R Cast-in socket	Annex C4
Performances Characteristic resistance to tension load under fire exposure	

Table C6: Characteristic resistance to shear load in cracked and uncracked concrete under fire exposure¹⁾

Size		HCX-R M16
Effective embedment depth	h_{ef} [mm]	50
Steel failure without lever arm		
Characteristic resistance	$V_{Rk,s,fi(30)}$ [kN]	4,71
	$V_{Rk,s,fi(60)}$ [kN]	3,93
	$V_{Rk,s,fi(90)}$ [kN]	3,14
	$V_{Rk,s,fi(120)}$ [kN]	2,51
Steel failure with lever arm		
Characteristic resistance	$M^0_{Rk,s,fi(30)}$ [Nm]	9,99
	$M^0_{Rk,s,fi(60)}$ [Nm]	8,33
	$M^0_{Rk,s,fi(90)}$ [Nm]	6,66
	$M^0_{Rk,s,fi(120)}$ [Nm]	5,33
Concrete pryout failure		
Pryout factor	k_8 [-]	1,0
Characteristic resistance $\geq C20/25$	$V_{Rk,cp,fi(30)}$ [kN]	3,75
	$V_{Rk,cp,fi(60)}$ [kN]	3,75
	$V_{Rk,cp,fi(90)}$ [kN]	3,75
	$V_{Rk,cp,fi(120)}$ [kN]	3,01
Concrete edge failure		
Effective length of fastener under shear loading	$l_f = h_{ef}$ [mm]	50
Outside diameter of fastener	d_{nom} [mm]	22

¹⁾ Design under fire exposure is performed according to the design method given in EOTA TR 020. Under fire exposure usually cracked concrete is assumed. The design equations are given in EOTA TR 020, Section 2.2.2.

EOTA TR 020 covers design for fire exposure from one side. For fire attack from more than one side the edge distance must be increased to $c_{min} \geq 300$ mm and $\geq 2 \cdot h_{ef}$.

HCX-R Cast-in socket	Annex C5
Performances Characteristic resistance to shear load under fire exposure	



British Board of Agrément,
Bucknalls Lane,
Watford,
Hertfordshire
WD25 9BA