

UL INTERNATIONAL (UK) LTD
Kingsland Business Park,
Unit 1-3 Horizon,
Wade Rd,
Basingstoke RG24 8AH,
United Kingdom

appointed according to Article 29 of Construction Products Regulation 2011 as amended by the Construction Products (Amendment etc.) (EU Exit) Regulations 2019 and the Construction Products (Amendment etc.) (EU Exit) Regulations 2020

UK Technical Assessment

0843-UKTA-22/0043
of 31/03/2023

Technical Assessment Body Issuing the UKTA:

UL International (UK) Ltd

Trade name of the construction product

Hilti Firestop Collar CFS-C P

Product family to which the construction product belongs

Fire Stopping and Fire Sealing Products - Penetration Seals

Manufacturer

Hilti Corporation
Feldkircherstrasse 100
9494 Schaan
LIECHTENSTEIN

Manufacturing plant(s)

HILTI production plant 4a
HILTI production plant 5a
HILTI production plant 5b

This UK Technical Assessment contains

41 pages including Annexes 1 to 4 which form an integral part of this assessment

This UK Technical Assessment* is issued, on the basis of

EAD 350454-00-1104, September 2017

Translations of this UK Technical Assessment in other languages shall fully correspond to the original issued document and should be identified as such.

Communication of this UK Technical Assessment, including transmission by electronic means, shall be in full. However, partial reproduction may be made, with the written consent of the issuing Technical Assessment Body. Any partial reproduction shall be identified as such.

* in accordance with Construction Products Regulation 2011 as amended by the Construction Products (Amendment etc.) (EU Exit) Regulations 2019 and the Construction Products (Amendment etc.) (EU Exit) Regulations 2020

Content

1	Technical description of the product	3
2	Specification of the intended use(s) in accordance with the applicable UK Assessment Document (Pre-Exit European Assessment Document): EAD 350454-00-1104	4
3	Performance of the product and references to the methods used for its assessment	6
4	Assessment and verification of constancy of performance (hereinafter AVCP) system applied, with reference to its legal base	9
5	Technical details necessary for the implementation of the AVCP system, as provided for in the applicable EAD	9
	ANNEX 1: DESCRIPTION OF THE PRODUCT AND ANCILLARY PRODUCT(S)	11
	ANNEX 2: RESISTANCE TO FIRE CLASSIFICATION OF PENETRATION SEALS MADE OF HILTI FIRESTOP COLLAR CFS-C P.....	12
	ANNEX 3: INSTALLATION OF THE PRODUCT AND ANCILLARY PRODUCT(S)	39
	ANNEX 4: ABBREVIATIONS AND REFERENCE DOCUMENTS	40

SPECIFIC PARTS OF THE UK TECHNICAL ASSESSMENT

1 Technical description of the product

Hilti Firestop Collar CFS-C P is a pipe closure device installed around plastic pipes to form a penetration seal to reinstate the fire resistance performance of wall and floor constructions, where they have been provided with apertures for the penetration of services.

Ancillary products referred to in this UK Technical Assessment within the framework of evaluating resistance to fire (see Annexes 1 and 2) are not covered by this UKTA and cannot be UKCA-marked on the basis of it.

Type of penetration seal system: Pipe closure device - collar (see EAD 350454-00-1104, clause 1.1). Hilti Firestop Collar CFS-C P consists of a steel housing, an intumescent inlay and fastening hooks.

Hilti Firestop Collar CFS-C P is supplied in several sizes – see table below. The collar is installed underneath floors or on both sides of a wall and fixed by hooks and metal anchors.

Collar size	For pipes with nominal outside diameters (mm)	Recommended opening size (mm)	Required number of fastening hooks
CFS-C P 50/1.5"	50	62	2
CFS-C P 63/2"	63	77	2
CFS-C P 75/2.5"	75	82	3
CFS-C P 90/3"	90	112	3
CFS-C P 110/4"	110	122	4
CFS-C P 125/5"	125	142	4
CFS-C P 160/6"	160	182	6
CFS-C P 180/7"	180	210	8
CFS-C P 200/8"	200	230	8
CFS-C P 225/9"	227	260	10
CFS-C P 250/10"	250	280	12

For the purpose of smoke and draft stop, air or water tightness and airborne sound insulation, the gap between opening edge and pipe or collar has to be sealed off by gypsum plaster, cementitious mortar or a construction sealant, the latter optionally in combination with mineral wool as backfilling material, considering the detailed prescriptions given in Annexes 1 and 2.

In case sound decoupling between the pipe and the wall/floor is required, but sound decoupling means around the pipe are missing, it is recommended to use Hilti Firestop Acrylic Sealant CFS-S ACR (UKTA-22/0045) as an annular gap seal. If gypsum plaster or cementitious mortar is intended to be used it is recommended to install a PE foam strip around the pipe over the entire wall or floor thickness for sound decoupling of the pipe. For details see Annexes 1 and 2.

In case air permeability data according to 3.2.1 or airborne sound insulation data according to 3.4.1 are intended to be used, Hilti Firestop Acrylic Sealant CFS-S ACR must be used to seal off the annular gap between pipe and opening edge.

For a description of the installation procedure see Annex 2 and Annex 3.

2 Specification of the intended use(s) in accordance with the applicable UK Assessment Document (Pre-Exit European Assessment Document): EAD 350454-00-1104

2.1 Intended use

The Hilti Firestop Collar CFS-C P is intended to form a part of a penetration seal, which is used to maintain the fire resistance of a separating element (flexible wall, rigid wall or rigid floor) when and where services pass through.

Annex 2 gives details of penetration seals for which fire resistance tests were carried out. This UKTA covers assemblies installed in accordance with the provisions given in Annex 2.

Hilti Firestop Collar CFS-C P may be used to provide a penetration seal with plastic and composite pipes as single penetrations. For details on diameters, wall thicknesses, pipe materials and pipe standards see Annex 2.

Pipes shall be perpendicular to the seal surface. The pipe penetration seal is intended for plastic pipes in piping systems for non-combustible liquids and fluids, for pneumatic dispatch systems and for pipes in centralised vacuum-cleaning systems.

The assessment does not cover the avoidance of destruction of the seal or of the abutting building element(s) by forces caused by temperature changes in case of fire. This has to be considered when designing the piping system.

The Hilti Firestop Collar CFS-C P is intended for environmental conditions as defined by use category Z₂, internal conditions with humidity lower than 85% RH excluding temperatures below 0°C, without exposure to rain or UV according to EOTA TR 024.

The provisions made in this UK Technical Assessment are based on an assumed working life of Hilti Firestop Collar CFS-C P of 10 years provided the conditions laid down in sections 4 and 5 relating to manufacturing, installation, use and repair are met. The indications given on the working life cannot be interpreted as a guarantee given by the producer, but are to be regarded only as a means for choosing the right products in relation to the expected economically reasonable working life of the works.

2.2 Use category

Hilti Firestop Collar CFS-C P is intended for use in internal conditions with humidity lower than 85 % RH excluding temperatures below 0° C, without exposure to rain or UV, and can therefore - according to EAD 350454-00-1104, clause 1.2.1 - be categorized as Type Z₂.

2.3 General Assumptions

For evaluating resistance to fire of penetration seals using Hilti Firestop Collar CFS-C P as specified in Annex 2 it is assumed that

- the installation of the penetration seal does not affect the stability of the adjacent building elements – even in case of fire,
- the installations are fixed to the adjacent building elements (not to the seal) in accordance with the relevant regulations in such a way that, in case of fire, no additional mechanical load is imposed on the seal,
- the support of the installations is maintained for the classification period required and
- pneumatic dispatch systems, compressed air systems, etc. are switched off by additional means in case of fire.

This UK Technical Assessment does not address any risks associated with the emission of dangerous liquids or gases caused by failure of the pipe(s) in case of fire nor does it prove the prevention of the transmission of fire through heat transfer via the medium in the pipes.

This UK Technical Assessment does not verify the prevention of destruction of adjacent building elements with fire separating function or of the pipes themselves due to distortion forces caused by extreme temperatures. These risks shall be accounted for by taking appropriate measures when designing or installing the pipe work.

The mounting or hanging of the pipes or the layout of the pipe work shall be implemented in such a way that the pipes and the fire-resistant building elements shall remain functional for at least the target period of fire resistance.

The risk of downward spread of fire caused by burning material which drips through a pipe to floors below, is not considered in this UKTA (see EN 1366-3: 2021, section 1).

The durability assessment does not take account of the possible effect on the penetration seal of substances permeating through pipe walls.

2.4 Manufacturing

The UK Technical Assessment is issued for the product on the basis of agreed data/information, deposited with UL International (UK) Ltd, which identifies the product that has been assessed and judged. Changes to the product or production process, which could result in this deposited data/information being incorrect, should be notified to UL International (UK) Ltd before the changes are introduced.

UL International (UK) Ltd will decide whether or not such changes affect the UK Technical Assessment and consequently the validity of the UKCA marking on the basis of the UK Technical Assessment and if so whether further Assessment or alterations to the UK Technical Assessment, shall be necessary.

2.5 Installation

The arrangement and installation of Hilti Firestop Collar CFS-C P shall be done in accordance with the details given in Annex 2 and Annex 3 for the penetration seal(s).

Performance of the product and references to the methods used for its assessment

Basic requirements for construction works	Essential characteristic	Method of verification	Performance
BWR 2	Reaction to fire	EN 13501-1	Clause 3.1.1 of this UKTA
	Resistance to fire	EN 13501-2	See Annex 2 of this UKTA
BWR 3	Air permeability	Clause 3.2.1 of this UKTA	
	Water permeability	Clause 3.2.2 of this UKTA	
	Content and/or release of dangerous substances	Declaration of conformity by the manufacturer	
BWR 4	Mechanical resistance and stability	No performance assessed	
	Resistance to impact/movement	No performance assessed	
	Adhesion	Clause 3.3.3 of this UKTA	
BWR 5	Airborne sound insulation	Clause 3.4.1 of this UKTA	
BWR 6	Thermal properties	No performance assessed	
	Water vapour permeability	No performance assessed	

3.1 Safety in case of fire (BWR 2)

3.1.1 Reaction to fire

“Hilti Firestop Collar CFS-C P” is classified ‘E’ in accordance with EN 13501-1.

3.1.2 Resistance to fire

The resistance to fire performance according to EN 13501-2 of penetration seals made of Hilti Firestop Collar CFS-C P is given in Annex 2.

Information on ancillary products which were tested within the framework of this UK Technical Assessment for evaluating resistance to fire is given in Annex 1.

3.2 Hygiene, health and environment (BWR 3)

3.2.1 Air permeability

Air tightness for a single penetration of a plastic pipe, fire stopped with Hilti Firestop Collar CFS-C P can only be achieved when the annular gap is sealed with a sealant, e.g. using Hilti Firestop Acrylic Sealant CFS-S ACR.

The air permeability of “Hilti Firestop Acrylic Sealant CFS-S ACR” with a thickness of 25 mm on both sides of the wall was tested according to EN 1026:2000 and EN 12211:2000 in an aerated concrete wall. The dimension of the tested joint was 1000 mm x 50 mm.

Up to a pressure difference of 9700 Pa no air permeability was measured.

3.2.2 Water permeability

Water tightness for a single penetration of a plastic pipe, fire stopped with Hilti Firestop Collar CFS-C P can only be achieved when the annular gap is sealed with a sealant, e.g. using Hilti Firestop Acrylic Sealant CFS-S ACR.

The water permeability of Hilti Firestop Acrylic Sealant CFS-S ACR has been tested according to the principles given in Annex C of EAD 350454-00-1104. The specimen consisted of 2 mm Hilti Firestop Acrylic Sealant CFS-S ACR (dry film thickness) on mineral wool. Test result: Water tight to 1000 mm head of water or 9806 Pa.

For annular gaps sealed with cementitious mortar or gypsum plaster no performance has been assessed.

3.2.3 Content, emission and/or release of dangerous substances.

The manufacturer has provided a declaration on the content, emission and/or release of dangerous substances in relation to their products with the title “Statement on Product Regulatory Compliance: Version 1.1 October 2022).

In addition to the specific clauses relating to dangerous substances contained in this UK Technical Assessment, there may be other requirements applicable to the products falling within its scope (e.g. transposed UK legislation and national laws, regulations and administrative provisions). In order to meet the provisions of the Construction Products Regulation, these requirements need also to be complied with, when and where they apply.

3.3 Safety and accessibility in use (BWR 4)

3.3.1 Mechanical resistance and stability

No performance assessed.

3.3.2 Resistance to impact / movement

No performance assessed.

3.3.3 Adhesion

The fixing of the collars (number of hooks, material and dimensions of fasteners) must be done according to the provisions given in Annex 2 and Annex 3.

3.4 Protection against noise (BWR 5)

3.4.1 Airborne sound insulation

Airborne sound insulation for a single penetration of a plastic pipe, fire stopped with Hilti Firestop Collar CFS-C P can only be achieved when the annular gap is sealed. It has to be noted that the values given below, for a seal formed from Hilti Firestop Acrylic Sealant CFS-S ACR, are only valid if the annular gap is sealed using stone wool as backfilling material (which is not necessary in all cases for fire resistance – see Annex 2).

Annular gap seal with Hilti Firestop Acrylic Sealant CFS-S ACR

Test reports from noise reduction according to EN ISO 10140-1:2010+A1:2012+A2:2014, EN ISO 10140-2:2010 and EN ISO 717-1:2013 have been provided. The tests were performed in a joint (length 1200mm, depth 100mm, width 25mm) in a rigid wall backfilled with compressed mineral wool. Installation depth of “Hilti Firestop Acrylic Sealant CFS-S ACR” was 12mm on both sides of the wall.

The reached values for the airborne sound insulation are given in the following table.

R_{s,w} in dB	C in dB	C_{tr} in dB
64	-2	-7

3.5 Energy economy and heat retention (BWR 6)

3.5.1 Thermal properties

No performance assessed.

3.5.2 Water vapour permeability

No performance assessed.

4 Assessment and verification of constancy of performance (hereinafter AVCP) system applied, with reference to its legal base

According to the Statutory Instrument 2019 No. 465 – made 5th March 2019 and cited as the Construction Products (Amendment etc.) (EU Exit) Regulations 2019 and coming into force on exit day and Statutory Instrument 2020 No. 1359 – made 26th November 2020 and cited as the Construction Products (Amendment etc.) (EU Exit) Regulations 2020 and coming into force immediately before the 2019 Regulations come into force, on the procedure for attesting the conformity of construction products as regards fire stopping, fire sealing and fire protective products, published as 'Pre-Exit' European Assessment Documents, (see <https://www.gov.uk/guidance/pre-exit-european-assessment-documents-construction-products>), the system of assessment and verification of constancy of performance (see Annex V to Construction Products Regulation 2011 as amended by the Construction Products (Amendment etc.) (EU Exit) Regulations 2019 and the Construction Products (Amendment etc.) (EU Exit) Regulations 2020) given in the following table(s) apply.

Product(s)	Intended use(s)	Level(s) or class(es)	System
Fire Stopping and Fire Sealing Products	For fire compartmentation and/or fire protection or fire performance	any	1

5 Technical details necessary for the implementation of the AVCP system, as provided for in the applicable EAD

Tasks of the manufacturer:
Factory production control

The manufacturer shall exercise permanent internal control of production. All the elements, requirements and provisions adopted by the manufacturer shall be documented in a systematic manner in the form of written policies and procedures, including records of results performed. This production control system shall ensure that the product is in conformity with this UK Technical Assessment.

The manufacturer may only use initial / raw / constituent materials stated in the technical documentation of this UK Technical Assessment.

The factory production control shall be in accordance with the Control Plan of 11/01/2022 relating to the UK Technical Assessment 0843-UKTA-22/0043 issued on 31/03/2023 which is part of the technical documentation of this UK technical Assessment. The "Control Plan" is laid down in the context of the factory production control system operated by the manufacturer and deposited at UL International (UK) Ltd.

The results of factory production control shall be recorded and evaluated in accordance with the provisions of the Control Plan.

Other tasks of the manufacturer
Additional information

The manufacturer shall provide a technical data sheet and an installation instruction with the following minimum information:

(a) Technical data sheet:

- Field of application:
- Building elements for which the penetration seal is suitable, type and properties of the building elements like minimum thickness, density, and - in case of lightweight constructions – the construction requirements.
- Limits in size, minimum thickness etc. of the penetration seal
- Construction of the penetration seal including the necessary components and additional products (e.g. backfilling material) with clear indication whether they are generic or specific.
- Services which the penetration seal is suitable, type and properties of the services like material, diameter, thickness etc. in case of pipes including insulation materials; necessary/allowed supports/fixings (e.g. pipe trays)

(b) Installation instruction:

- Steps to be followed
- Procedure in case of retrofitting
- Stipulations on maintenance, repair and replacement

Issued on: 31st March 2023

Report by:



C. Sweeney
Project Engineer Associate
Built Environment

For and on behalf of UL International (UK) Ltd.

Reviewed by:



D. Yates
Senior Project Engineer
Built Environment

ANNEX 1: DESCRIPTION OF THE PRODUCT AND ANCILLARY PRODUCT(S)

1.1 Product

Hilti Firestop Collar CFS-C P

The housing of the collar consists of electrolytic galvanized steel, the inlay consists of one or more intumescent strips. A detailed specification of the product is contained in document "Identification / Product Specification relating to UKTA – 10/0404 Hilti Firestop Collar CFS-C P" which is a non-public part of this UKTA.

The Control Plan is defined in document "Control Plan of 11.01.2022 relating to UKTA-22/0043 - Hilti Firestop Collar CFS-C P" which is a non-public part of this UKTA.

Technical product literature:

- Technical Data Sheet Hilti Firestop Collar CFS-C P (including the use of ancillary products according to Annex 1.2).

1.2 Ancillary products

1.2.1 Hilti Firestop Acrylic Sealant CFS-S ACR

A detailed specification of the product is contained in document "Identification / Product Specification and Control Plan of 27.10.2010 relating to UKTA-22/0045 and UKTA-22/0046 - Hilti Firestop Acrylic Sealant CFS-S ACR" which is a non-public part of the referenced UKTAs.

1.2.2 Gypsum plaster

Any gypsum plaster suitable for use with flexible wall constructions or the intended type of rigid walls or floors may be used.

1.2.3 Cementitious mortar

Any cementitious mortar suitable for use with the intended type of rigid walls or floors may be used.

1.2.4 Mineral wool

Loose mineral wool products suitable for being used as backfilling material of Hilti Firestop Acrylic Sealant CFS-S ACR

Product	Manufacturer	Specification
Heralan LS	Knauf Insulation GmbH	Product data sheet of Knauf
Isover loose wool SL	Saint-Gobain ISOVER	Product data sheet of Isover
Isover Universal-Stopfwolle	Saint-Gobain ISOVER	Product data sheet of Isover
Rockwool RL	Rockwool	Product data sheet of Rockwool
Paroc Pro Loose Wool	Paroc OY AB	Product data sheet of Paroc

1.2.5 Suitable insulation product – reaction to fire

Combustible insulation (closed cell flexible elastomeric foam, e.g. AF/Armaflex)	Minimum B-s3, d0 (acc. to EN 13501-1)
Combustible insulation for sound decoupling (elastomeric foam, e.g. PE)	Minimum E (acc. to EN 13501-1)

ANNEX 2: RESISTANCE TO FIRE CLASSIFICATION OF PENETRATION SEALS MADE OF HILTI FIRESTOP COLLAR CFS-C P

Intended use of pipes¹ and reference to relevant section

Application	Pipe material	Manufacturer, product	Insulation	see section					
				Flexible and rigid wall ≥ 100 mm	Rigid wall ≥ 150 mm	Rigid floor ≥ 550 kg/m ³	Rigid floor ≥ 2400 kg/m ³		
Heating	Al-Composite	Geberit Mepla	-	-	-	2.4.2.1.1	2.3.2.1.1		
			CS	2.1.2.1	2.1.2.1	2.4.2.1.2	2.3.2.1.2		
		KeKelit KELOX KM 110	CS	2.1.2.2	2.1.2.2	2.4.2.2	2.3.2.2		
		Rehau Rautitan stabil	CS	2.1.2.3	2.1.2.3	2.4.2.3	2.3.2.3		
	PE-X	Rehau Rautitan flex	CS	2.1.3.5	2.1.3.5	2.4.3.3	2.3.3.5		
Potable water	Al-Composite	Geberit Mepla	-	-	-	2.4.2.1.1	2.3.2.1.1		
			CS	2.1.2.1	2.1.2.1	2.4.2.1.2	2.3.2.1.2		
			KeKelit KELOX KM 110	CS	2.1.2.2	2.1.2.2	2.4.2.2	2.3.2.2	
		Rehau Rautitan stabil	CS	2.1.2.3	2.1.2.3	2.4.2.3	2.3.2.3		
		PE	EN 12201-2	-	2.1.3.1	2.1.3.1, 2.2.1	-	2.3.3.1	
		PE-HD 100 RC	Wavin TS	-	2.1.3.4.1	2.1.3.4.1	-	2.3.3.4.1	
				CS/LS	2.1.3.4.2	2.1.3.4.2	-	2.3.3.4.2	
		PE-X	Rehau Rautitan flex	CS	2.1.3.5	2.1.3.5	2.4.3.3.1	2.3.3.5	
		PP	EN ISO 15874 (e.g. Aquatherm green Aquatherm green faserverbund	-	2.1.4.1.1, 2.1.4.1.2	2.1.4.1.1, 2.1.4. 1.2	2.4.4.1.1, 2.4.4.1.2	2.3.4.1.1, 2.3.4.1.2	
	CS/LS			2.1.4.1.3	2.1.4.1.3	2.4.4.1.3	2.3.4.1.3		
CS/LS	2.1.4.3			2.1.4.3					
		CS/LS	2.1.4.4	2.1.4.4		2.3.4.1			
	PVC-C	Friatherm starr	CS/LS	2.1.5.2	2.1.5.2	-	2.3.5.3		
Refrige-ration	ABS	+GF+ COOL-FIT	CS	2.1.1	-	2.4.1	2.3.1		
Waste water Roof Drainage	PE	EN 1519, EN 12666-1	-	2.1.3.1.1	2.1.3.1, 2.2.1	-	2.3.3.1		
			Cl/CS	2.1.3.1.2 2.1.3.1.3					
	PE-HD 1000 RC	Wavin TS	-	2.1.3.4.1	2.1.3.4.1	2.4.3.2	2.3.3.4.1		
			CS/LS	2.1.3.4.2	2.1.3.4.2	-	2.3.3.4.2		
	PE-S2	Geberit Silent db20	-	2.1.3.3	2.1.3.3	2.4.4.5	2.3.3.3		
	PP	EN 1451-1	Aquatherm blue Aquatherm blue faserverbund	-	2.1.4.5	2.1.4.5	-	2.3.4.2	
				-	2.1.4.1	2.1.4.1		2.3.4.1	
				Magnaplast Skolan dB	-	2.1.4.1	2.1.4.1	-	2.3.4.3
				Pipelife Master 3	-	2.1.4.1	2.1.4.1	2.4.4.2	2.3.4.1
				Poloplast Polo Kal NG	-	2.1.4.1	2.1.4.1, 2.2.4	2.4.4.3	2.3.4.1
				Poloplast Polo Kal 3S	-	2.1.4.1	2.1.4.1	2.4.4.4	2.3.4.1
				Rehau Raupiano Plus	-	2.1.4.1	2.1.4.1, 2.2.4	-	2.3.4.4
				Wavin AS/KeKelit "Phonex AS"	-	2.1.4.1	2.1.4.1, 2.2.4	-	2.3.4.5
Wavin SiTech	-	2.1.4.1	2.1.4.1	-	2.3.4.6				
PVC-C	EN 1566-1	-	2.1.5.1	2.1.5.1	2.4.5.1	2.3.5.1			
PVC-U	EN ISO 1452, EN 1329-1, EN 1453-1	-	2.1.5.1	2.1.5.1	2.4.5.1	2.3.5.1			
Pneumatic	Al-composite	Geberit Mepla	-	-	-	2.4.2.1	2.3.2.1.1		
	PP	-	-	2.1.4.1.1,	2.1.4.1.1,	2.4.4.1	2.3.4.1.1		

¹ According to technical literature of pipe manufacturers
0843-UKTA-22/0043 of 31/03/2023 – Page 12 of 41

Application	Pipe material	Manufacturer, product	Insulation	see section			
				Flexible and rigid wall ≥ 100 mm	Rigid wall ≥ 150 mm	Rigid floor ≥ 550 kg/m ³	Rigid floor ≥ 2400 kg/m ³
				2.1.4.1.2	2.1.4.1.2		
Sprinkler	PP-R	Aquatherm red	-	2.1.4.1.1, 2.1.4.1.2	2.1.4.1.1, 2.1.4.1.2	2.4.4.1	2.3.4.1
Industry	Al-Composite		-	2.1.2	2.1.2	2.4.2	2.3.2
	PE	EN ISO 15494	-	2.1.3.2	2.1.3.2, 2.2.2	2.4.3.1	2.3.3.2
	PP	-	-	2.1.4.1	2.1.4.1	2.4.4.1	2.3.4.1
		Aquatherm blue Aquatherm blue faserverbund	-	2.1.4.1	2.1.4.1	2.4.4.1	2.3.4.1
	PVC-U	EN ISO 15493	-	2.1.5.1	2.1.5.1, 2.2.3	2.4.5.1	2.3.5.1

2.1 Flexible and rigid walls, minimum wall thickness 100 mm

Flexible walls:

The wall must have a minimum thickness of 100 mm and comprise timber or steel studs lined on both faces with minimum 2 layers of 12,5 mm thick boards. For timber stud walls there must be a minimum distance of 100 mm of the seal to any stud and the cavity between stud and seal must be closed and minimum 100 mm insulation of Class A1 or A2 (in accordance with EN 13501-1) in the cavity between stud and seal.

Rigid walls:

The wall must have a minimum thickness of 100 mm and minimum density of 450 kg/m³ and comprise concrete, aerated concrete or masonry.

Penetration seal:

Single penetration;

Hilti Firestop Collar CFS-C P (A₁) on both sides.

Annular gap filled with:

Flexible walls:

Gypsum plaster (A₃) over the entire thickness of the wall or

Hilti Firestop Acrylic Sealant CFS-S ACR (A₂) on both sides with a depth of minimum 25 mm from the surface of the wall.

Rigid walls:

Gypsum plaster (A₃) or cementitious mortar over the entire thickness of the wall or

Hilti Firestop Acrylic Sealant CFS-S ACR (A₂) on both sides with a depth of minimum 15 mm from the surface of the wall. The sealant may be backfilled with mineral wool.

Width of annular gap: The opening diameter should not be larger than the collar outside diameter to allow a safe fixing of the collar to the wall.

Distance between penetrations:

Minimum distance between collars / annular gap (s₁):

Non-insulated pipes: 0 mm

Insulated pipes: 0 mm

Collars to be fixed with hooks (F) and threaded rods M8 through the wall and nuts on both sides of the wall. In high density rigid walls alternatively metal anchors with minimum \varnothing 8 mm may be used.

For minimum number of hooks see section 1.

Pipes shall be supported at maximum 300 mm away from both faces of wall constructions.

Sound decoupling: Sound decoupling strips (C₁) based on combustible insulation (elastomeric foam, e.g. PE) minimum E (acc. to EN 13501-1), used in combination with gypsum plaster or mortar as gap filler. Sound decoupling installed around the pipe within the wall. For maximum thickness see tables below.

Pipe insulation: Combustible insulation (closed cell flexible elastomeric foam, e.g. AF/Armaflex), reaction to fire minimum B-s3, d0 (acc. to EN 13501-1) installed in wall application. For maximum thickness see tables below.

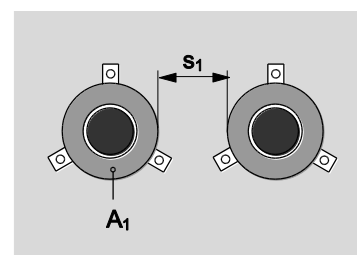

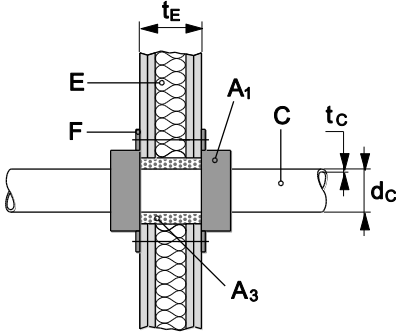
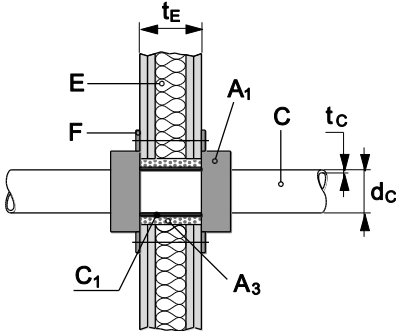
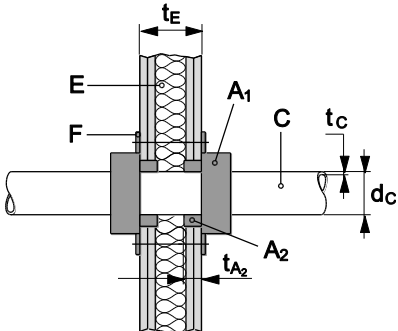
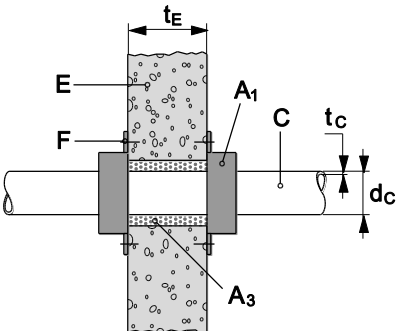
<p>Annular gap seal (drawings show non-insulated pipes as example)</p>	
<p>Gypsum plaster (A₃)</p>	
<p>Gypsum plaster (A₃) together with sound decoupling (C₁)</p>	
<p>Hilti Firestop Acrylic Sealant CFS-S ACR (A₂)</p>	
<p>Gypsum plaster or cementitious mortar (A₃)</p>	

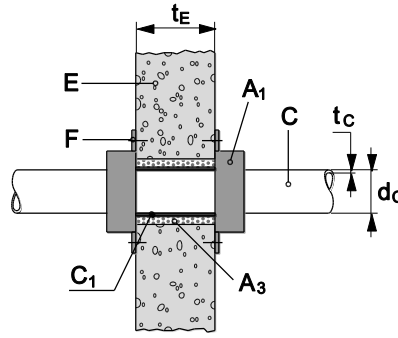
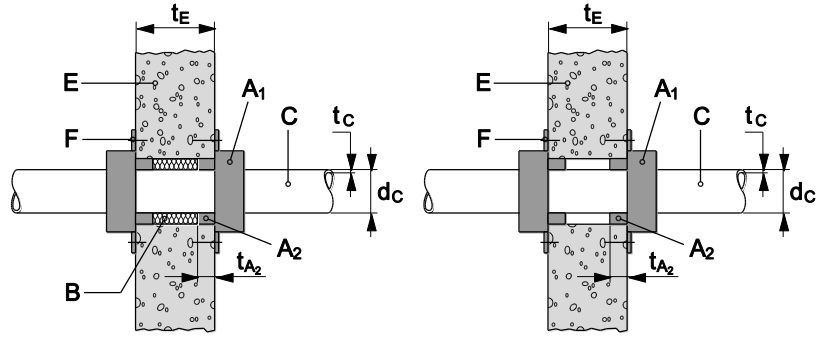
<p>Gypsum plaster or cementitious mortar (A₃) together with sound decoupling (C₁)</p>	
<p>Hilti Firestop Acrylic Sealant CFS-S ACR (A₂)</p>	

Pipe insulation
(drawings show mortar as an example for the annular gap seal)

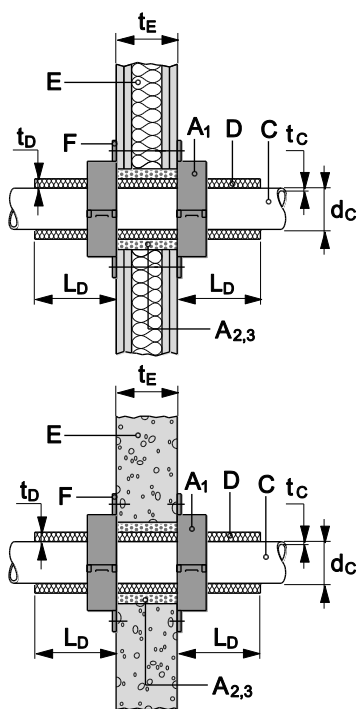
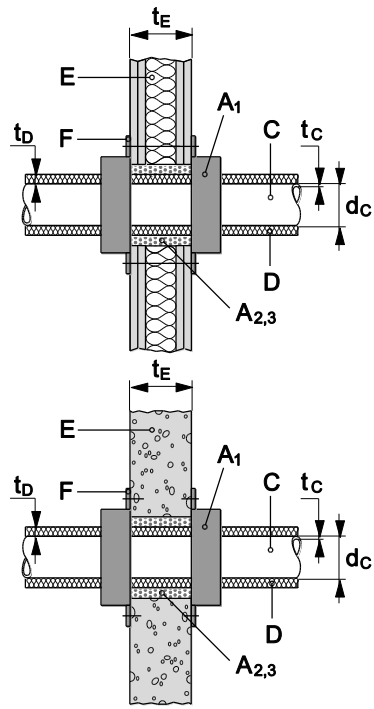
Local/Sustained pipe insulation (LS)	Continued/Sustained pipe insulation (CS)
	

Penetrating services				
2.1.1 ABS pipes +GF+ "COOL-FIT" (ABS/PUR insulation/PE-HD)				
Pipe diameter d_c (mm)	Inner pipe diameter (mm)		Collar size (A_1)	Classification
90	32		CFS-C P 90/3"	EI 120-U/C
110	40		CFS-C P 110/4"	EI 120-U/C
110	50		CFS-C P 110/4"	EI 120-U/C
160	90		CFS-C P 160/6"	EI 120-U/C
180	110		CFS-C P 180/7"	EI 120-U/C
225	140		CFS-C P 225/9"	EI 120-U/C
250	160		CFS-C P 250/10"	EI 60-U/C
2.1.2 Al-composite pipes				
2.1.2.1 Geberit "Mepla" pipes (PE-Xb/Al/PE-HD)				
Combustible insulation (D) - arrangement CS				
Pipe diameter d_c (mm)	Pipe wall thickness t_c (mm)	Insulation thickness t_D (mm)	Collar size (A_1)	Classification
16	2,0	11,5	CFS-C P 50/1.5"	EI 120-U/C
20	2,5	11,5 - 13	CFS-C P 63/2"	EI 120-U/C
26	3,0	11,5 - 13	CFS-C P 63/2"	EI 120-U/C
32	3,0	13	CFS-C P 63/2"	EI 120-U/C
40	3,5	9	CFS-C P 63/2"	EI 120-U/C
50	4,0	9	CFS-C P 63/2"	EI 120-U/C
63	4,5	10	CFS-C P 75/2.5"	EI 60-U/C
75	4,7	10	CFS-C P 90/3"	EI 90-U/C
2.1.2.2 KeKelit "KELOX KM 110" pipes (PE-X/Al/PE-X)				
Combustible insulation (D) - arrangement CS				
Pipe diameter d_c (mm)	Pipe wall thickness t_c (mm)	Insulation thickness t_D (mm)	Collar size (A_1)	Classification
16	2,0	11,5	CFS-C P 50/1.5"	EI 120-U/C
20	2,25	11,5 - 13	CFS-C P 63/2"	EI 120-U/C
25	2,5	11,5 - 13	CFS-C P 63/2"	EI 120-U/C
32	3,0	13	CFS-C P 63/2"	EI 120-U/C
32	3,0	9	CFS-C P 50/1.5"	EI 90-U/C
40	4,0	9	CFS-C P 50/1.5"	EI 90-U/C
50	4,5	9	CFS-C P 63/2"	EI 90-U/C
63	6,0	10	CFS-C P 75/2.5"	EI 90-U/C

2.1.2.3 Rehau "Rautitan stabil" pipes (PE-Xb/Al/PE-HD)				
Combustible insulation (D) - arrangement CS				
Pipe diameter d_c (mm)	Pipe wall thickness t_c (mm)	Insulation thickness t_D (mm)	Collar size (A_1)	Classification
16	2,6	11,5	CFS-C P 50/1.5"	EI 120-U/C
20	2,9	11,5 - 13	CFS-C P 63/2"	EI 120-U/C
25	3,7	11,5 - 13	CFS-C P 63/2"	EI 120-U/C
32	4,7	13	CFS-C P 63/2"	EI 120-U/C
40	6,0	9	CFS-C P 63/2"	EI 120-U/C

2.1.3 PE pipes				
2.1.3.1 PE pipes according to EN 1519-1				
2.1.3.1.1 Without insulation				
Pipe diameter d_c (mm)	Pipe wall thickness t_c (mm)	Collar size (A_1)	Classification	
50	3,0	CFS-C P 50/1.5"	EI 120-U/U	
63	3,0	CFS-C P 63/2"	EI 120-U/U	
75	3,0	CFS-C P 75/2.5"	EI 120-U/U	
90	3,5	CFS-C P 90/3"	EI 120-U/U	
110	4,2	CFS-C P 110/4"	EI 120-U/U	
125	4,8	CFS-C P 125/5"	EI 120-U/U	
160	6,2	CFS-C P 160/6"	EI 120-U/U	
Maximum thickness of sound decoupling: 5 mm				
The results of 2.1.2.2 are also valid for PE pipes according to EN 12201-2 and EN 12666-1.				
2.1.3.1.2 Insulation (D): Foamed elastomeric insulation – arrangement CI				
Pipe diameter d_c (mm)	Pipe wall thickness t_c (mm)	Insulation thickness t_D (mm)	Collar size (A_1)	Classification
110	4,2	10	CFS-C P 125/5"	EI 90-U/U
2.1.3.1.3 Insulation (D): Foamed elastomeric insulation – arrangement CS				
Pipe diameter d_c (mm)	Pipe wall thickness t_c (mm)	Insulation thickness t_D (mm)	Collar size (A_1)	Classification
110	4,2	25	CFS-C P 160/6"	EI 90-U/U

2.1.3.2 PE pipes according to EN ISO 15494			
Pipe diameter d_c (mm)	Pipe wall thickness t_c (mm)	Collar size (A_1)	Classification
50	2,9 – 4,6	CFS-C P 50/1.5"	EI 120-U/U
63	1,8 – 5,8	CFS-C P 63/2"	EI 90-U/U
63	3,6 – 5,8	CFS-C P 63/2"	EI 120-U/U
75	1,9 – 6,8	CFS-C P 75/2.5"	EI 120-U/U
90	2,2 – 8,2	CFS-C P 90/3"	EI 120-U/U
110	2,7 – 10,0	CFS-C P 110/4"	EI 120-U/U
125	3,1 – 7,1	CFS-C P 125/5"	EI 120-U/U
160	4,0 – 9,1	CFS-C P 160/6"	EI 120-U/U
Maximum thickness of sound decoupling: 5 mm			

2.1.3.3 Geberit "Silent dB20" pipes (PE-S2)			
Pipe diameter d_c (mm)	Pipe wall thickness t_c (mm)	Collar size (A_1)	Classification
56	3,2	CFS-C P 63/2"	EI 120-U/U
63	3,2	CFS-C P 63/2"	EI 120-U/U
75	3,6	CFS-C P 75/2.5"	EI 120-U/U
90	5,6	CFS-C P 90/3"	EI 120-U/U
110	6,0	CFS-C P 110/4"	EI 120-U/U
Maximum thickness of sound decoupling: 9 mm			
2.1.3.3.1 Pipe end configuration C/U			
Pipe diameter d_c (mm)	Pipe wall thickness t_c (mm)	Collar size (A_1)	Classification
135	6,0	CFS-C P 160/6"	EI 120-C/U
160	7,0	CFS-C P 160/6"	EI 120-C/U
Maximum thickness of sound decoupling: 9 mm			

2.1.3.4 Wavin "TS" pipes (PE-HD 100 RC)				
2.1.3.4.1 Without insulation				
Pipe diameter d_c (mm)	Pipe wall thickness t_c (mm)	Collar size (A_1)	Classification	
50	4,6	CFS-C P 50/1.5"	EI 90-U/U	
75	6,8	CFS-C P 75/2.5"	EI 120-U/U	
90	8,2	CFS-C P 90/3"	EI 120-U/U	
110	10,0	CFS-C P 110/4"	EI 120-U/U	
Maximum thickness of sound decoupling: 9 mm				
2.1.3.4.2 Combustible insulation (D) - arrangement LS (length of insulation $L_D \geq 250$ mm) or CS				
Pipe diameter d_c (mm)	Pipe wall thickness t_c (mm)	Insulation thickness t_D (mm)	Collar size (A_1)	Classification
50	4,6	9	CFS-C P 63/2"	EI 120-U/C
63	5,8	10	CFS-C P 75/2.5"	EI 120-U/C
75	6,8	10	CFS-C P 90/3"	EI 120-U/C
90	8,2	10	CFS-C P 110/4"	EI 120-U/C
110	10,0	10	CFS-C P 125/5"	EI 120-U/C

2.1.3.5 PE-X pipes				
2.1.3.5.1 Rehau "Rautitan flex" pipes (PE-Xa)				
Combustible insulation (D) - arrangement LS (length of insulation $L_D \geq 250$ mm) or CS				
Pipe diameter d_c (mm)	Pipe wall thickness t_c (mm)	Insulation thickness t_D (mm)	Collar size (A_1)	Classification
40	5,5	9	CFS-C P 63/2"	EI 120-U/C
50	6,9	9	CFS-C P 63/2"	EI 120-U/C
63	8,6	10	CFS-C P 75/2.5"	EI 120-U/C

2.1.4 PP pipes				
2.1.4.1 PP pipes according to EN ISO 15874² (e.g. Aquatherm blue , Aquatherm blue Faserverbundrohr, Aquatherm red , Aquatherm green , Aquatherm green Faserverbundrohr, +GF+ PROGEF Standard pipe, +GF+ Dekaprop Industry pipe)				
2.1.4.1.1 Without insulation – pipe end configuration U/U				
Pipe diameter d_c (mm)	Pipe wall thickness t_c (mm)		Collar size (A_1)	Classification
50	1,8 - 2,9		CFS-C P 50/1.5"	EI 90-U/U
63	1,8 - 5,8		CFS-C P 63/2"	EI 60-U/U
75	1,9 – 6,8		CFS-C P 75/2,5"	EI 60-U/U
75	6,8 - 12,5		CFS-C P 75/2.5"	EI 120 U/U
90	8,2 - 15,0		CFS-C P 90/3"	EI 120 U/U
110	2,7		CFS-C P 110/4"	EI 120 U/U
2.1.4.1.2 Without insulation – pipe end configuration U/C				
50	4,6 - 8,3		CFS-C P 50/1.5"	EI 90-U/C
63	5,8 - 10,5		CFS-C P 63/2"	EI 60-U/C
63	10,5		CFS-C P 63/2"	EI 120 U/C
75	1,9- 6,8		CFS-C P 75/2.5"	EI 60 U/C
75	6,8 – 12,5		CFS-C P 75/2.5"	EI 120 U/C
Maximum thickness of sound decoupling: 9 mm				
2.1.4.1.3 Combustible insulation (D) - arrangement LS (length of insulation $L_D \geq 250$ mm) or CS				
Pipe diameter d_c (mm)	Pipe wall thickness t_c (mm)	Insulation thickness t_D (mm)	Collar size (A_1)	Classification
40	3,7 - 5,5	9	CFS-C P 50/1.5"	EI 120 U/C
50	4,6 - 6,9	9	CFS-C P 63/2"	EI 120 U/C
75	6,8 - 10,3	10	CFS-C P 90/3"	EI 120 U/C
90	10,0 - 15,1	22,5	CFS-C P 125/5"	EI 120 U/C

² Not all listed wall thicknesses may be available for pipes according to EN ISO 15874

2.1.4.3 Aquatherm "green " pipes with insulationPipe series SDR 11; Combustible insulation (D) - arrangement LS (length of insulation $L_D \geq 250$ mm) or CS

Pipe diameter d_c (mm)	Pipe wall thickness t_c (mm)	Insulation thickness t_D (mm)	Collar size (A_1)	Classification
40	3,7	9	CFS-C P 50/1.5"	EI 120-U/C
50	4,6	9	CFS-C P 63/2"	EI 120-U/C
75	6,8	10	CFS-C P 90/3"	EI 120-U/C
110	10,0	10	CFS-C P 125/5"	EI 120-U/C

2.1.4.4 Aquatherm "green Faserverbundrohr" pipes with insulationCombustible insulation (D) – arrangement LS (length of insulation $L_D \geq 250$ mm) or CS

Pipe diameter d_c (mm)	Pipe wall thickness t_c (mm)	Insulation thickness t_D (mm)	Collar size (A_1)	Classification
40	5,5	9	CFS-C P 50/1.5"	EI 120-U/C
50	6,9	9	CFS-C P 63/2"	EI 120-U/C
75	10,3	10	CFS-C P 90/3"	EI 120-U/C
110	15,1	10	CFS-C P 125/5"	EI 120-U/C

2.1.4.5 PP pipes according to EN 1451-1(e.g. **Ostendorf** "Skolan-dB", "Phonex AS", Pipelife "Master 3", POLOPLAST "Polo Kal NG", POLOPLAST "Polo Kal 3S", Rehau "Raupiano Plus", Wavin "AS" /KeKelit "Phonex AS", Wavin "SiTech", Cloes "Blue Power", Cloes "PhoNoFire", Valsire "Triplus", Valsire "Silere", Marley "Silent", "Geberit Silent PP")

Pipe diameter d_c (mm)	Pipe wall thickness t_c (mm)	Collar size (A_1)	Classification
32	1,8	CFS-C P 50/1.5"	EI 120-U/U
40	1,8	CFS-C P 50/1.5"	EI 120-U/U
50	1,8 - 2,0	CFS-C P 50/1.5"	EI 120-U/U
56	4,0	CFS-C P 63/2"	EI 90-U/U
70	4,5	CFS-C P 75/2.5"	EI 120-U/U
75	1,8 - 3,8	CFS-C P 75/2.5"	EI 120-U/U
90	2,8 - 4,5	CFS-C P 90/3"	EI 120-U/U
110	2,7 - 5,3	CFS-C P 110/4"	EI 120 U/U

Maximum thickness of sound decoupling: 9 mm

2.1.5 PVC pipes**2.1.5.1 PVC-U pipes according to EN ISO 15493 and EN ISO 1452**

Pipe diameter d_c (mm)	Pipe wall thickness t_c (mm)	Collar size (A_1)	Classification
50	2,4 – 5,6	CFS-C P 50/1.5"	EI 120-U/U
63	3,0 – 4,7	CFS-C P 63/2"	EI 120-U/U
75	2,2 – 3,6	CFS-C P 75/2.5"	EI 120-U/U
90	2,7 – 4,3	CFS-C P 90/3"	EI 120-U/U
110	2,2 – 8,1	CFS-C P 110/4"	EI 120-U/U
125	3,7 – 6,0	CFS-C P 125/5"	EI 120-U/U
160	2,5 – 11,8	CFS-C P 160/6"	EI 120-U/U

Maximum thickness of sound decoupling: 5 mm

The results of 2.1.5.1 are also valid for PVC-C pipes according to EN 1566-1³ and PVC-U pipes according to EN 1329-1 and EN 1453-1

2.1.5.2 Friatec Friatherm-starr pipes (PVC-C)

Combustible insulation (D) - arrangement LS (length of insulation $L_D \geq 200$ mm) or CS

Pipe diameter d_c (mm)	Pipe wall thickness t_c (mm)	Insulation thickness t_D (mm)	Collar size (A_1)	Classification
32	3,6	9	CFS-C P 50/1.5"	EI 120-U/C
40	4,5	9	CFS-C P 63/2"	EI 120-U/C
50	5,6	9	CFS-C P 75/2.5"	EI 120-U/C
63	7,1	10	CFS-C P 90/3"	EI 120-U/C

³ It is recommended only to use gypsum plaster or cementitious mortar as annular gap seal for PVC-C pipes together with sound decoupling according to Annex 1.2.5

2.2 Rigid walls, minimum wall thickness 150 mm

The wall must have a minimum thickness of 150 mm and a minimum density of 650 kg/m³ and comprise concrete, aerated concrete or masonry.

Penetration seal:

Single penetration;

Hilti Firestop Collar CFS-C P (A₁) on both sides.

Annular gap filled either with gypsum plaster or cementitious mortar (A₃) over the entire thickness of the wall or with Hilti Firestop Acrylic Sealant CFS-S ACR (A₂) with a depth of minimum 15 mm from the surface of the wall. The sealant may be backfilled with mineral wool.

Width of annular gap: The opening diameter should not be larger than the collar outside diameter to allow a safe fixing of the collar to the wall except stated otherwise in the table below.

Distance between penetrations:

Minimum distance between collars / annular gap edge (s₁):

Non insulated pipes: 0 mm

Insulated pipes: 0 mm

Collars to be fixed with hooks (F) and M8 metal anchors. In high density rigid walls alternatively metal anchors with minimum Ø 8 mm may be used. For minimum number of hooks see section 1.

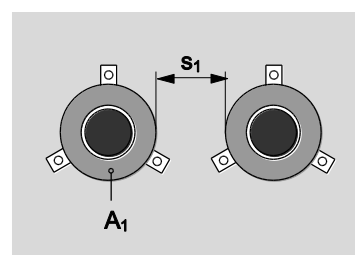

Sound decoupling: Sound decoupling strips (C₁) based on combustible insulation (elastomeric foam, e.g. PE) minimum E (acc. to EN 13501-1), used in combination with gypsum plaster or mortar as gap filler. Sound decoupling installed around the pipe within the wall. For maximum thickness see tables below.

For further construction details see 2.1.

Penetrating services

2.2.1 PE pipes according to EN 1519-1

Pipe diameter d _c (mm)	Pipe wall thickness t _c (mm)	Collar size (A ₁)	Classification
200	6,2	CFS-C P 200/8"	EI 120 U/U
250	7,8	CFS-C P 250/10"	EI 120 U/U

Maximum thickness of sound decoupling: 5 mm

The results of 2.2.1 are also valid for PE pipes according to EN 12201-2 and EN 12666-1.

2.2.2 PE pipes according to EN ISO 15494

Distance between pipe and seal edge in wall (width of annular gap): ≤ 17,5 mm

2.2.2.1 Pipe end configuration U/U

Pipe diameter d _c (mm)	Pipe wall thickness t _c (mm)	Collar size (A ₁)	Classification
180	4,4 – 16,4	CFS-C P 180/7"	EI 120-U/U
200	4,9 – 11,4	CFS-C P 200/8"	EI 120-U/U
200	11,4	CFS-C P 200/8"	EI 180-U/U
225	5,5 – 12,8	CFS-C P 225/9"	EI 180-U/U
250	6,2 – 14,2	CFS-C P 250/10"	EI 180-U/U

2.2.2.2 Pipe end configuration U/C

50	2,9	CFS-C P 50/1.5"	EI 180-U/C
250	7,8	CFS-C P 250/10"	EI 180-U/C
250	7,8 – 22,7	CFS-C P 250/10"	EI 120-U/C

Maximum thickness of sound decoupling: 5 mm

2.2.3 PVC-U pipes according to EN ISO 15493 and EN ISO 1452Distance between pipe and seal edge in floor (width of annular gap): $\leq 17,5$ mm**2.2.3.1 Pipe end configuration U/U**

Pipe diameter d_c (mm)	Pipe wall thickness t_c (mm)	Collar size (A_1)	Classification
180	3,6 – 8,6	CFS-C P 180/7"	EI 180 U/U
200	4,0 – 9,6	CFS-C P 200/8"	EI 180 U/U
225	4,5 – 10,8	CFS-C P 225/9"	EI 180 U/U
250	4,9 – 11,9	CFS-C P 250/10"	EI 180 U/U

2.2.3.2 Pipe end configuration U/C

50	1,8	CFS-C P 50/1.5"	EI 180-U/C
250	4,9 – 11,9	CFS-C P 250/10"	EI 180-U/C

The results of 2.2.3 are also valid for PVC-C pipes according to EN 1566-1³ and PVC-U pipes according to EN 1329-1^{Error! Bookmark not defined.} and EN 1453-1^{Error! Bookmark not defined.}.

2.2.4 PP pipes according to EN 1451-1

(e.g. **Ostendorf** "Skolan-dB", "Phonex AS", Pipelife "Master 3", POLOPLAST "Polo Kal NG", POLOPLAST "Polo Kal 3S", Rehau "Raupiano Plus", Wavin "AS" /KeKelit "Phonex AS", Wavin "SiTech", Cloes "Blue Power", Cloes "PhoNoFire", Valsire "Triplus", Valsire "Silere", Marley "Silent" ", "Geberit Silent PP")

Distance between pipe and seal edge in wall (width of annular gap): ≤ 30 mm

Pipe diameter d_c (mm)	Pipe wall thickness t_c (mm)	Collar size (A_1)	Classification
200	6,2 - 6,8	CFS-C P 200/8"	EI 120-C/U
250	8,6	CFS-C P 250/10"	EI 120-C/U

Maximum thickness of sound decoupling: 9 mm

2.3 Rigid floor, minimum density of 2400 kg/m³

The floor must have a minimum thickness of 150 mm and comprise concrete with a minimum density of 2400 kg/m³.

Penetration seal:

Single penetration;

Hilti Firestop Collar CFS-C P (A₁) on the underside of the floor.

Annular gap filled either with gypsum plaster or cementitious mortar (A₃) over the entire thickness of the floor or with mineral wool of minimum density 60 kg/m³ covered by Hilti Firestop Acrylic Sealant CFS-S ACR (A₂) on top side (or on both sides) with a depth of minimum 10 mm.

Width of annular gap:

Classifications EI 120 and lower (opening diameter up to 300 mm), classification EI 180 (opening diameter up to 260 mm): The opening diameter should not be larger than the collar outside diameter to allow a safe fixing of the collar to the floor. Classification EI 180 (opening diameter > 260 mm): see in tables below.

Distance between penetrations:

Minimum distance between collars / annular gap edge (s₁):

Non-insulated pipes: 0 mm

Insulated pipes: 0 mm

Collars to be fixed with hooks and metal anchors with minimum \varnothing 6 mm (up to collar size 110/4") and minimum \varnothing 10 mm (from collar size 125/5" to 250/10"). For minimum number of hooks see section 1.

Pipes shall be supported at maximum 200 mm (pipes according to 2.3.1), at maximum 300 mm (all others) away from the upper face of the floor construction.

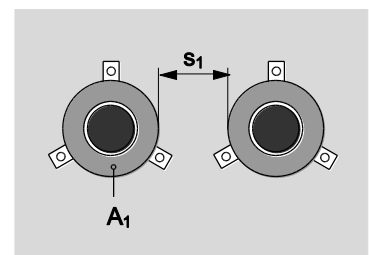

Sound decoupling: Sound decoupling strips (C₁) based on combustible insulation (elastomeric foam, e.g. PE) minimum E (acc. to EN 13501-1), used in combination with gypsum plaster or mortar as gap filler. Sound decoupling installed around the pipe within the floor. For maximum thickness see tables below.

Pipe insulation: Combustible insulation (closed cell flexible elastomeric foam, e.g. AF/Armaflex), reaction to fire minimum B-s3, d0 (acc. to EN 13501-1) installed in floor application. For maximum thickness see table below.

Annular gap seal (drawings show non-insulated pipes as example)	
Gypsum plaster or cementitious mortar (A ₃)	
Cementitious mortar (A ₃) together with sound decoupling (C ₁)	

Hilti Firestop Acrylic Sealant CFS-S ACR (A₂)

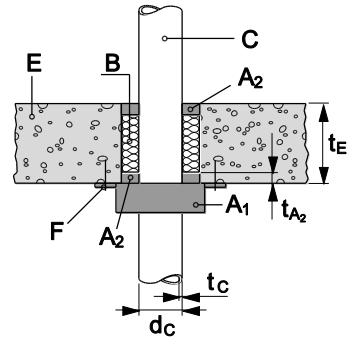

Pipe insulation

(drawings show mortar as an example for the annular gap seal)

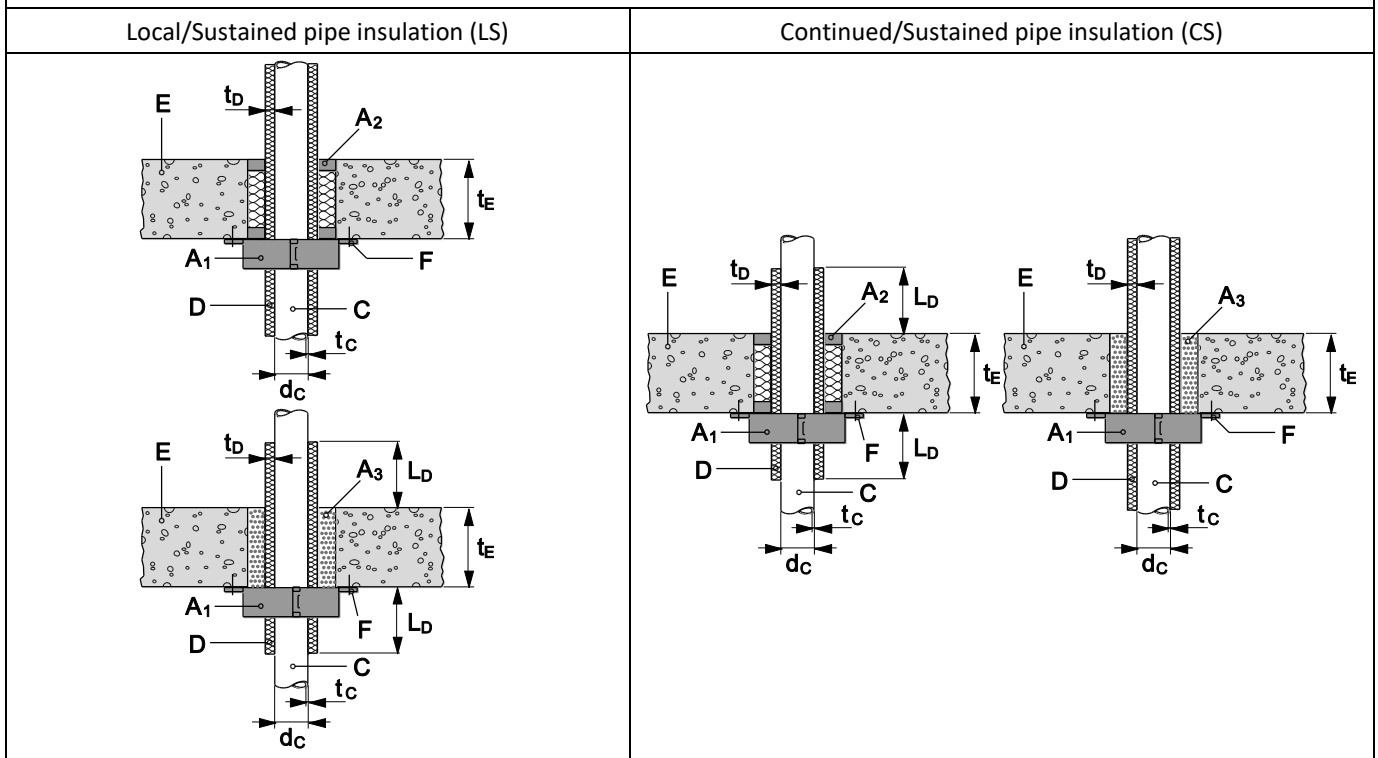

Penetrating services

2.3.1 ABS pipes +GF+ "COOL-FIT" (ABS/PUR insulation/PE-HD)

Pipe diameter d_c (mm)	Inner pipe diameter (mm)	Collar size (A_1)	Classification
90	32	CFS-C P 90/3"	EI 120-U/C
110	40	CFS-C P 110/4"	EI 120-U/C
110	50	CFS-C P 110/4"	EI 120-U/C
160	90	CFS-C P 160/6"	EI 120-U/C
180	110	CFS-C P 180/7"	EI 60-U/C
225	140	CFS-C P 225/9"	EI 120-U/C
250	160	CFS-C P 250/10"	EI 120-U/C

2.3.2 Al-composite pipes

2.3.2.1 Geberit "Mepla" pipes (PE-Xb/Al/PE-HD)

2.3.2.1.1 Without insulation

Pipe diameter d_c (mm)	Pipe wall thickness t_c (mm)	Collar size (A_1)	Classification
40	3.5	CFS-C P 50/1.5"	EI 90-U/C
50	4.0	CFS-C P 50/1.5"	EI 120-U/C
63	4.5	CFS-C P 63/2"	EI 60-U/C
75	4.7	CFS-C P 75/2.5"	EI 30-U/C
110	6.0	CFS-C P 110/4"	EI 180-U/C

Maximum thickness of sound decoupling: 9 mm

2.3.2.1.2 Combustible insulation (D) - arrangement LS (length of insulation $L_D \geq 250$ mm) or CS				
Pipe diameter d_c (mm)	Pipe wall thickness t_c (mm)	Insulation thickness t_D (mm)	Collar size (A_1)	Classification
40	3.5	9	CFS-C P 63/2"	EI 180-U/C
50	4.0	9	CFS-C P 63/2"	EI 180-U/C
63	4.5	9	CFS-C P 75/2.5"	EI 180-U/C
75	4.7	10	CFS-C P 90/3"	EI 180-U/C
40	3.5	9 - 20,5	CFS-C P 63/2" - 75/2.5"	EI 120-U/C
50	4.0	9 - 21	CFS-C P 63/2" - 90/3"	EI 120-U/C
63	4.5	9 - 21,5	CFS-C P 75/2.5" - 110/4"	EI 120-U/C
75	4.7	10 - 22	CFS-C P 90/3" - 125/5"	EI 120-U/C
2.3.2.2 KeKelit "KELOX KM 110" pipes (PE-X/Al/PE-X)				
Combustible insulation (D) - arrangement CS				
Pipe diameter d_c (mm)	Pipe wall thickness t_c (mm)	Insulation thickness t_D (mm)	Collar size (A_1)	Classification
32	3.0	9	CFS-C P 50/1.5"	EI 180-U/C
40	4.0	9	CFS-C P 50/1.5"	EI 180-U/C
50	4.5	9	CFS-C P 63/2"	EI 180-U/C
63	6.0	10	CFS-C P 75/2.5"	EI 120-U/C
Combustible insulation (D) - arrangement CS				
32	3.0	9 – 19,5	CFS-C P 50/1.5" - 75/2.5"	EI 120-U/C
40	4.0	9 – 20,5	CFS-C P 50/1.5" - 75/2.5"	EI 120-U/C
50	4.5	9 - 21	CFS-C P 63/2" - 90/3"	EI 120-U/C
63	6.0	10 – 21,5	CFS-C P 75/2.5" - 110/4"	EI 120-U/C
Combustible insulation (D) - arrangement LS (length of insulation $L_D \geq 250$ mm)				
32	3.0	19,5	CFS-C P 75/2.5"	EI 120-U/C
40	4.0	20,5	CFS-C P 75/2.5"	EI 120-U/C
50	4.5	21	CFS-C P 90/3"	EI 120-U/C
63	6.0	21,5	CFS-C P 110/4"	EI 120-U/C
2.3.2.3 Rehau "Rautitan stabil" pipes (PE-Xb/Al/PE-HD)				
Combustible insulation (D) - arrangement LS (length of insulation $L_D \geq 250$ mm) or CS				
Pipe diameter d_c (mm)	Pipe wall thickness t_c (mm)	Insulation thickness t_D (mm)	Collar size (A_1)	Classification
40	6,0	9	CFS-C P 63/2"	EI 180-U/C
40	6,0	9 - 20,5	CFS-C P 63/2" - 75/2.5"	EI 120-U/C

2.3.3 PE pipes			
2.3.3.1 PE pipes according to EN 1519-1 <small>Error! Bookmark not defined.</small>			
Pipe diameter d _c (mm)	Pipe wall thickness t _c (mm)	Collar size (A ₁)	Classification
50	3,0	CFS-C P 50/1.5"	EI 120-U/U
63	3,0	CFS-C P 63/2"	EI 120-U/U
75	3,0	CFS-C P 75/2.5"	EI 120-U/U
90	3,5	CFS-C P 90/3"	EI 120-U/U
110	4,2	CFS-C P 110/4"	EI 120-U/U
125	4,8	CFS-C P 125/5"	EI 120-U/U
160	6,2	CFS-C P 160/6"	EI 120-U/U
200	6,2	CFS-C P 200/8"	EI 120-U/U
250	7,7	CFS-C P 250/10"	EI 120-U/U
Maximum thickness of sound decoupling: 5 mm			
The results of 2.3.3.3 are also valid for PE pipes according to EN 12201-2 and EN 12666-1.			
2.3.3.2 PE pipes according to EN ISO 15494			
2.3.3.2.1 Pipe end configuration U/U			
Pipe diameter d _c (mm)	Pipe wall thickness t _c (mm)	Collar size (A ₁)	Classification
20 *)	1,9 – 2,8	CFS-C P 50/1.5"	EI 90-U/U
20 - 50	1,9 / 2,9 - 2,8 / 4,6 ⁴	CFS-C P 50/1.5"	EI 90-U/U
50	2,9 – 4,6	CFS-C P 50/1.5"	EI 120-U/U
63	1,8 – 5,8	CFS-C P 63/2"	EI 120-U/U
75	1,9 – 6,8	CFS-C P 75/2.5"	EI 120-U/U
90	2,2 – 8,2	CFS-C P 90/3"	EI 120-U/U
110	2,7 – 10,0	CFS-C P 110/4"	EI 120-U/U
125	3,1 – 7,1	CFS-C P 125/5"	EI 120-U/U
160	4,0 – 9,1	CFS-C P 160/6"	EI 120-U/U
2.3.3.2.2 Pipe end configuration U/C			
180	4,4 – 16,4	CFS-C P 180/7"	EI 120-U/C
200	4,9 – 11,4	CFS-C P 200/8"	EI 120-U/C
225	5,5 – 12,8	CFS-C P 225/9"	EI 120-U/C
250	6,2 – 22,7	CFS-C P 250/10"	EI 120-U/C
50	2,9	CFS-C P 50/1.5"	EI 180-U/C
250	7,8	CFS-C P 250/10"	EI 180-U/C
Maximum thickness of sound decoupling: 5 mm, for pipes indicated with *): 9 mm			

⁴ Interpolation of minimum wall thickness between 1,9 mm for diameter 20 mm and 2,9 mm for diameter 50 mm, interpolation of maximum wall thickness between 2,8 mm for diameter 20 mm and 4,6 mm for diameter 50 mm for pipe diameters in between.

2.3.3.2.3 2 Pipes in 1 collar

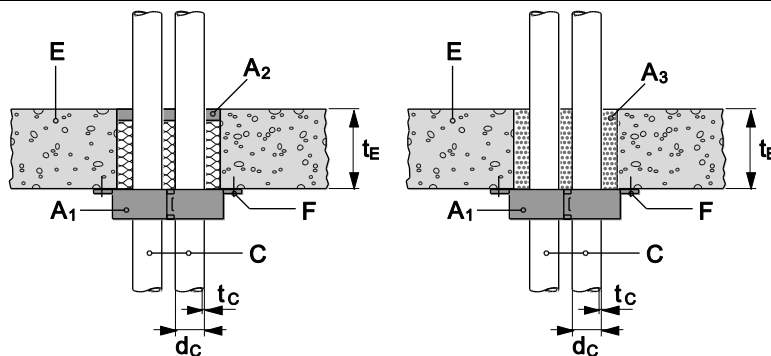

20	1,9	CFS-C P 50/1.5"	EI 90-U/U
20	2,8		

2.3.3.3 Geberit "Silent dB20" pipes (PE-S2)

Pipe diameter d_c (mm)	Pipe wall thickness t_c (mm)	Collar size (A_1)	Classification
75	3,6	CFS-C P 75/2.5"	EI 180-U/U
90	5,5	CFS-C P 90/3"	EI 180-U/U
110	6,0	CFS-C P 110/4"	EI 180-U/U
135	6,0	CFS-C P 160/6"	EI 120-U/U
160	7,0	CFS-C P 160/6"	EI 180-U/U

Maximum thickness of sound decoupling: 9 mm

2.3.3.4 Wavin "TS" pipes (PE-HD 100 RC)

2.3.3.4.1 Without insulation

Pipe diameter d_c (mm)	Pipe wall thickness t_c (mm)	Collar size (A_1)	Classification
50	4,6	CFS-C P 50/1.5"	EI 90-U/U
63	5,8	CFS-C P 63/2"	EI 120-U/U
75	6,8	CFS-C P 75/2.5"	EI 120-U/U
90	8,2	CFS-C P 90/3"	EI 120-U/U
110	10,0	CFS-C P 110/4"	EI 120-U/U

Maximum thickness of sound decoupling: 9 mm

2.3.3.4.2 Combustible insulation (D) - arrangement LS (length of insulation $L_D \geq 250$ mm) or CS

Pipe diameter d_c (mm)	Pipe wall thickness t_c (mm)	Insulation thickness t_D (mm)	Collar size (A_1)	Classification
50	4,6	9	CFS-C P 63/2" or 75/2.5"	EI 180-U/C
63	5,8	10	CFS-C P 75/2.5"	EI 180-U/C
75	6,8	10	CFS-C P 90/3"	EI 180-U/C
90	8,2	9,5	CFS-C P 110/4"	EI 180-U/C
110	10,0	9,5	CFS-C P 125/5"	EI 180-U/C

2.3.3.5 PE-X pipes				
2.3.3.5.1 Rehau "Rautitan flex" pipes (PE-Xa)				
Combustible insulation (D) - arrangement LS (length of insulation $L_D \geq 250$ mm) or CS				
Pipe diameter d_c (mm)	Pipe wall thickness t_c (mm)	Insulation thickness t_D (mm)	Collar size (A_1)	Classification
40	6,0	9	CFS-C P 63/2"	EI 180-U/C
50	6,9	9	CFS-C P 75/2.5"	EI 180-U/C
63	8,6	9	CFS-C P 90/3"	EI 180-U/C
40	6,0	9 - 20,5	CFS-C P 63/2" - 75/2.5"	EI 120-U/C
50	6,9	9 - 21	CFS-C P 75/2.5" - 90/3"	EI 120-U/C
63	8,6	9 - 21,5	CFS-C P 90/3" - 110/4"	EI 120-U/C

2.3.4 PP pipes				
2.3.4.1 PP pipes according to EN ISO 15874⁵				
(e.g. Aquatherm blue , Aquatherm blue Faserverbundrohr, Aquatherm red , Aquathermgreen , Aquatherm green Faserverbundrohr, +GF+ PROGEF Standard pipe, +GF+ Dekaprop Industry pipe)				
2.3.4.1.1 Without insulation - pipe end configuration U/U				
Pipe diameter d_c (mm)	Pipe wall thickness t_c (mm)	Collar size (A_1)	Classification	
20	1,9 - 3,4	CFS-C P 50/1.5"	EI 120-U/U	
50	1,8 - 2,9	CFS-C P 50/1.5"	EI 180-U/U	
63	1,8 - 5,8	CFS-C P 63/2"	EI 180-U/U	
75	1,9 - 6,8	CFS-C P 75/2.5"	EI 180-U/U	
90	2,2 - 8,2	CFS-C P 90/3"	EI 180-U/U	
110	2,7	CFS-C P 110/4"	EI 180-U/U	
125	3,1	CFS-C P 125/5"	EI 180-U/U	
2.3.4.1.2 Without insulation - pipe end configuration U/C				
40	3,7 - 5,5	CFS-C P 50/1.5"	EI 120-U/C	
50	4,6 - 8,3	CFS-C P 50/1.5"	EI 180-U/C	
63	5.8 - 10,5	CFS-C P 63/2"	EI 180-U/C	
75	6,8	CFS-C P 75/2.5"	EI 180-U/C	
75	6,8 - 12,5	CFS-C P 75/2.5"	EI 120-U/C	
90	8,2	CFS-C P 90/3"	EI 180-U/C	
90	8,2 - 15,0	CFS-C P 90/3"	EI 120-U/C	
110	10,0 - 15,1	CFS-C P 110/4"	EI 120-U/C	
Maximum thickness of sound decoupling: 9 mm				

⁵ Not all listed wall thicknesses may be available for pipes according to EN ISO 15874

2.3.4.1.3 Combustible insulation (D) – arrangement LS (length of insulation LD ≥ 250 mm) or CS				
Pipe diameter d _c (mm)	Pipe wall thickness t _c (mm)	Insulation thickness t _D (mm)	Collar size (A ₁)	Classification
40	3,7 - 5,5	9	CFS-C P 63/2"	EI 180-U/C
50	4,6 - 6,9	9	CFS-C P 75/2.5"	EI 180-U/C
75	6,8 - 10,3	10	CFS-C P 90/3"	EI 180-U/C
90	12,3	22,5	CFS-C P 160/6"	EI 120-U/C
110	10,0 - 15,1	10	CFS-C P 125/5"	EI 180-U/C

2.3.4.2 PP pipes according to EN 1451-1

(e.g. Magnaplast "Skolan-dB", "Phonex AS", Pipelife "Master 3", POLOPLAST "Polo Kal NG", POLOPLAST "Polo Kal 3S", Rehau "Raupiano Plus", Wavin "AS"/KeKelit "Phonex AS", Wavin "SiTech") Cloes "Blue Power", Cloes "PhoNoFire", Valsire "Triplus", Valsire "Silere", "Geberit Silent PP")

Pipe diameter d _c (mm)	Pipe wall thickness t _c (mm)	Collar size (A ₁)	Classification
32	1,2 - 1,8	CFS-C P 50/1.5"	EI 90-U/U
40	1,8	CFS-C P 50/1.5"	EI 90-U/U
50	1,8 - 2,0	CFS-C P 50/1.5"	EI 90-U/U
58	4,0	CFS-C P 63/2"	EI 90-U/U
75	1,9 - 4,5	CFS-C P 75/2.5"	EI 90-U/U
78	4,5	CFS-C P 75/2.5"	EI 90-U/U
90	2,8 - 4,5	CFS-C P 90/3"	EI 90-U/U
110	2,7 - 5,3	CFS-C P 110/4"	EI 90-U/U
125	3,9 - 5,3	CFS-C P 125/5"	EI 90-U/U
135	5,3	CFS-C P 160/6"	EI 90-U/U
160	4,9 - 5,3	CFS-C P 160/6"	EI 90-U/U

Maximum thickness of sound decoupling: 9 mm

2.3.4.3 Magnaplast "Skolan-dB" pipes

Pipe diameter d _c (mm)	Pipe wall thickness t _c (mm)	Collar size (A ₁)	Classification
58	4,0	CFS-C P 90/3"	EI 180-U/U
78	4,5	CFS-C P 75/2.5"	EI 180-U/U
90	4,5	CFS-C P 90/3"	EI 180-U/U
110	5,3	CFS-C P 110/4"	EI 180-U/U
135	5,3	CFS-C P 160/6"	EI 180-U/U
160	5,3	CFS-C P 160/6"	EI 180-U/U

Maximum thickness of sound decoupling: 9 mm

2.3.4.4 Rehau "Raupiano Plus" pipes (PP/PP-MV/PP)			
Pipe diameter d_c (mm)	Pipe wall thickness t_c (mm)	Collar size (A_1)	Classification
50	1,8	CFS-C P 50/1.5"	EI 180-U/U
75	1,9	CFS-C P 75/2.5"	EI 180-U/U
110	2,7	CFS-C P 110/4"	EI 180-U/U
Maximum thickness of sound decoupling: 9 mm			
2.3.4.5 Wavin "AS" /KeKelit "Phonex AS" pipes			
Pipe diameter d_c (mm)	Pipe wall thickness t_c (mm)	Collar size (A_1)	Classification
70	4,5	CFS-C P 75/2.5"	EI 180-U/U
90	4,5	CFS-C P 90/3"	EI 180-U/U
125	5,3	CFS-C P 125/5"	EI 180-U/U
160	5,3	CFS-C P 160/6"	EI 180-U/U
Maximum thickness of sound decoupling: 9 mm			
2.3.4.6 Wavin "SiTech" pipes			
Pipe diameter d_c (mm)	Pipe wall thickness t_c (mm)	Collar size (A_1)	Classification
75	2,3	CFS-C P 75/2.5"	EI 180-U/U
90	2,8	CFS-C P 90/3"	EI 180-U/U
125	3,9	CFS-C P 125/5"	EI 180-U/U
160	4,9	CFS-C P 160/6"	EI 180-U/U
Maximum thickness of sound decoupling: 9 mm			

2.3.5 PVC pipes				
2.3.5.1 PVC-U pipes according to EN ISO 15493 and EN ISO 1452				
2.3.5.1.1 Pipe end configuration U/U				
Pipe diameter d_c (mm)	Pipe wall thickness t_c (mm)	Collar size (A_1)	Classification	
20 *)	1,5 – 2,2	CFS-C P 50/1.5"	EI 120-U/U	
20 - 50	1,5/2,4 – 2,2/5,6 ⁶	CFS-C P 50/1.5"	EI 120-U/U	
50	2,4 – 5,6	CFS-C P 50/1.5"	EI 120-U/U	
63	3,0 – 4,7	CFS-C P 63/2"	EI 120-U/U	
75	2,2 – 3,6	CFS-C P 75/2.5"	EI 120-U/U	
90	2,7 – 4,3	CFS-C P 90/3"	EI 120-U/U	
110	1,8 – 8,1	CFS-C P 110/4"	EI 120-U/U	
125	3,7 – 6,0	CFS-C P 125/5"	EI 120-U/U	
160	2,5 – 11,8	CFS-C P 160/6"	EI 120-U/U	
180	3,6 – 8,6	CFS-C P 180/7"	EI 120-U/U	
200	4,0 – 9,6	CFS-C P 200/8"	EI 120-U/U	
225	4,5 – 10,8	CFS-C P 225/9"	EI 120-U/U	
250	4,9 – 11,9	CFS-C P 250/10"	EI 120-U/U	
Maximum thickness of sound decoupling: 5 mm, for pipes indicated with *): 9 mm				
2.3.5.1.2 Pipe end configuration U/C				
50	1,8	CFS-C P 50/1.5"	EI 180-U/C	
250	4,0 – 11,9	CFS-C P 250/10"	EI 180-U/C	
The results of 2.3.5.1 are also valid for PVC-C pipes according to EN 1566-1 ³ and PVC-U pipes according to EN 1329-1 ^{Error!} <small>Bookmark not defined.</small> and EN 1453-1 ^{Error!} <small>Bookmark not defined.</small>				
2.3.5.2 PVC-C pipes according to EN 1566-1				
See 2.3.5.1				
2.3.5.3 Friatec Friatherm-starr pipes (PVC-C)				
Combustible insulation (D) - arrangement LS (length of insulation $L_D \geq 200$ mm) or CS				
Pipe diameter d_c (mm)	Pipe wall thickness t_c (mm)	Insulation thickness t_D (mm)	Collar size (A_1)	Classification
32	3,6	9	CFS-C P 50/1.5"	EI 180-U/C
40	4,5	9	CFS-C P 63/2"	EI 180-U/C
50	5,6	9	CFS-C P 75/2.5"	EI 180-U/C
63	7,1	10	CFS-C P 90/3"	EI 180-U/C

⁶ Interpolation of minimum wall thickness between 1,5 mm for diameter 20 mm and 2,4 mm for diameter 50 mm, interpolation of maximum wall thickness between 2,2 mm for diameter 20 mm and 5,6 mm for diameter 50 mm for pipe diameters in between.

2.4 Rigid floors with a minimum density of 550 kg/m³

The floor must have a minimum thickness of 150 mm and comprise concrete or aerated concrete with a minimum density of 550 kg/m³.

For details of the penetration seal design see 2.3.

Pipes shall be supported at maximum 200 mm (pipes according to 2.4.1), at maximum 250 mm (all others) away from the upper face of the floor construction.

Penetrating services

2.4.1 ABS pipes +GF+ "COOL-FIT" (ABS/PUR insulation/PE-HD)

Pipe diameter d _c (mm)	Inner pipe diameter (mm)	Collar size (A ₁)	Classification
90	32	CFS-C P 90/3"	EI 120-U/C
110	40	CFS-C P 110/4"	EI 120-U/C
110	50	CFS-C P 110/4"	EI 120-U/C
160	90	CFS-C P 160/6"	EI 120-U/C
180	110	CFS-C P 180/7"	EI 60-U/C
225	140	CFS-C P 225/9"	EI 120-U/C
250	160	CFS-C P 250/10"	EI 120-U/C

2.4.2 Al-composite pipes

2.4.2.1 Geberit "Mepla" pipes (PE-Xb/Al/PE-HD)

2.4.2.1.1 Without insulation

Pipe diameter d _c (mm)	Pipe wall thickness t _c (mm)	Collar size (A ₁)	Classification
40	3.5	CFS-C P 50/1.5"	EI 90-U/C
50	4.0	CFS-C P 50/1.5"	EI 120-U/C
63	4.5	CFS-C P 63/2"	EI 60-U/C
75	4.7	CFS-C P 75/2.5"	EI 30-U/C

Maximum thickness of sound decoupling: 9 mm

2.4.2.1.2 Combustible insulation (D) - arrangement LS (length of insulation ≥ 250 mm) or CS

Pipe diameter d _c (mm)	Pipe wall thickness t _c (mm)	Insulation thickness t _b (mm)	Collar size (A ₁)	Classification
40	3.5	20,5	CFS-C P 63/2" - 75/2.5"	EI 120-U/C
50	4.0	21	CFS-C P 63/2" - 90/3"	EI 120-U/C
63	4.5	21,5	CFS-C P 75/2.5" - 110/4"	EI 120-U/C
75	4.7	22	CFS-C P 90/3" - 125/5"	EI 120-U/C

2.4.2.2 KeKelit "KELOX KM 110" pipes (PE-X/Al/PE-X)				
Combustible insulation (D) - Insulation arrangement LS (length of insulation \geq 250 mm)				
Pipe diameter d_c (mm)	Pipe wall thickness t_c (mm)	Insulation thickness t_D (mm)	Collar size (A_1)	Classification
32	3.0	19,5	CFS-C P 75/2.5"	EI 120-U/C
40	4.0	20,5	CFS-C P 75/2.5"	EI 120-U/C
50	4.5	21	CFS-C P 90/3"	EI 120-U/C
63	6.0	21,5	CFS-C P 110/4"	EI 120-U/C
2.4.2.3 Rehau "Rautitan stabil" pipes (PE-Xb/Al/PE-HD)				
Combustible insulation (D) - arrangement LS (length of insulation \geq 250 mm) or CS				
Pipe diameter d_c (mm)	Pipe wall thickness t_c (mm)	Insulation thickness t_D (mm)	Collar size (A_1)	Classification
40	6,0	20,5	CFS-C P 63/2" - 75/2.5"	EI 120-U/C
2.4.3 PE pipes				
2.4.3.1 PE pipes according to EN ISO 15494				
2.4.3.1.1 Pipe end configuration U/U				
Pipe diameter d_c (mm)	Pipe wall thickness t_c (mm)	Collar size (A_1)	Classification	
20 *)	1,9 – 2,8	CFS-C P 50/1.5"	EI 90-U/U	
20 - 50	1,9 / 2,9 - 2,8 / 4,6 ⁷	CFS-C P 50/1.5"	EI 90-U/U	
2.4.3.1.2 2 Pipes in 1 collar				
Pipe diameter d_c (mm)	Pipe wall thickness t_c (mm)	Collar size (A_1)	Classification	
20	1,9	CFS-C P 50/1.5"	EI 90-U/U	
20	2,8			
The results of 2.4.3.1 are also valid for PE pipes according to EN 1519-				
2.4.3.2 "Wavin TS" pipes (PE-HD 100 RC)				
Pipe diameter d_c (mm)	Pipe wall thickness t_c (mm)	Collar size (A_1)	Classification	
50	4,6	CFS-C P 50/1.5"	EI 90-U/U	
63	5,8	CFS-C P 63/2"	EI 120-U/U	
75	6,8	CFS-C P 75/2.5"	EI 120-U/U	
90	8,2	CFS-C P 90/3"	EI 120-U/U	
110	10,0	CFS-C P 110/4"	EI 120-U/U	
Maximum thickness of sound decoupling: 9 mm				

⁷ Interpolation of minimum wall thickness between 1,9 mm for diameter 20 mm and 2,9 mm for diameter 50 mm, interpolation of maximum wall thickness between 2,8 mm for diameter 20 mm and 4,6 mm for diameter 50 mm for pipe diameters in between.

2.4.3.3 PE-X pipes				
2.4.3.3.1 Rehau "Rautitan flex" pipes (PE-Xa)				
Combustible insulation (D) - arrangement LS (length of insulation ≥ 250 mm) or CS				
Pipe diameter d_c (mm)	Pipe wall thickness t_c (mm)	Insulation thickness t_D (mm)	Collar size (A_1)	Classification
40	6,0	20,5	CFS-C P 63/2" - 75/2.5"	EI 120-U/C
50	6,9	21	CFS-C P 75/2.5" - 90/3"	EI 120-U/C
63	8,6	21,5	CFS-C P 110/4"	EI 120-U/C
2.4.4 PP pipes				
2.4.4.1 PP pipes according to EN ISO 15874				
(e.g. Aquatherm blue, Aquatherm blue, Faserverbundrohr, Aquatherm red, Aquatherm green, Aquatherm green Faserverbundrohr, +GF+ PROGEF Standard pipe, +GF+ Dekaprop Industry pipe)				
2.4.4.1.1 Without insulation – pipe end configuration U/U				
Pipe diameter d_c (mm)	Pipe wall thickness t_c (mm)	Collar size (A_1)	Classification	
20	1,9 - 3,4	CFS-C P 50/1.5"	EI 120-U/U	
2.4.4.1.2 Without insulation – pipe end configuration U/C				
40	3,7 - 5,5	CFS-C P 50/1.5"	EI 120-U/C	
50	4,6 - 6,9	CFS-C P 50/1.5"	EI 120-U/C	
75	6,8	CFS-C P 75/2.5"	EI 120-U/C	
90	12,3	CFS-C P 90/3"	EI 120-U/C	
110	10,0 - 15,1	CFS-C P 110/4"	EI 120-U/C	
Maximum thickness of sound decoupling: 9 mm				
2.4.4.1.3 Combustible insulation (D) – arrangement LS (length of insulation $L_D \geq 250$ mm) or CS				
Pipe diameter d_c (mm)	Pipe wall thickness t_c (mm)	Insulation thickness t_D (mm)	Collar size (A_1)	Classification
90	12,3	22,5	CFS-C P 160/6"	EI 120-U/C
110	15,1	10	CFS-C P 125/5"	EI 120-U/C
2.4.4.2 Pipelife "Master 3" pipes (PP-CO/PP-MV/PP-CO)				
Pipe diameter d_c (mm)	Pipe wall thickness t_c (mm)	Collar size (A_1)	Classification	
32	1,2	CFS-C P 50/1.5"	EI 90-U/U	
40	1,8	CFS-C P 50/1.5"	EI 90-U/U	
50	1,8	CFS-C P 50/1.5"	EI 90-U/U	
75	1,8	CFS-C P 75/2.5"	EI 90-U/U	
110	1,8	CFS-C P 110/4"	EI 90-U/U	
Maximum thickness of sound decoupling: 9 mm				

2.4.4.3 POLOPLAST "Polo Kal NG" pipes (PP-CO/PP-MV/PP-CO)			
Pipe diameter d_c (mm)	Pipe wall thickness t_c (mm)	Collar size (A_1)	Classification
32	1,8	CFS-C P 50/1.5"	EI 90-U/U
40	1,8	CFS-C P 50/1.5"	EI 90-U/U
50	2,0	CFS-C P 50/1.5"	EI 90-U/U
75	2,6	CFS-C P 75/2.5"	EI 90-U/U
90	3,0	CFS-C P 90/3"	EI 90-U/U
110	3,6	CFS-C P 110/4"	EI 90-U/U
Maximum thickness of sound decoupling: 9 mm			
2.4.4.3.1 Without insulation – pipe end configuration C/U			
200	6,8	CFS-C P 200/8"	EI 180-C/U
250	8,6	CFS-C P 250/10"	EI 180-C/U
Maximum thickness of sound decoupling: 9 mm			
2.4.4.4 POLOPLAST "Polo Kal 3S" pipes (PP/PP-MV/PP)			
Pipe diameter d_c (mm)	Pipe wall thickness t_c (mm)	Collar size (A_1)	Classification
75	3,8	CFS-C P 75/2.5"	EI 90-U/U
90	4,5	CFS-C P 90/3"	EI 90-U/U
110	4,8	CFS-C P 110/4"	EI 90-U/U
Maximum thickness of sound decoupling: 9 mm			
2.4.4.5 Geberit "Silent dB20" pipes (PE-S2)			
Pipe diameter d_c (mm)	Pipe wall thickness t_c (mm)	Collar size (A_1)	Classification
56	3,2	CFS-C P 63/2"	EI 180-U/U
63	3,2	CFS-C P 63/2"	EI 180-U/U
110	6,0	CFS-C P 110/4"	EI 180-U/U
Maximum thickness of sound decoupling: 9 mm			
2.4.5 PVC pipes			
2.4.5.1 PVC-U pipes according to EN ISO 15493 and EN ISO 1452			
Pipe diameter d_c (mm)	Pipe wall thickness t_c (mm)	Collar size (A_1)	Classification
20 *)	1,5 – 2,2	CFS-C P 50/1.5"	EI 120-U/U
20 - 50	1,5/2,4 – 2,2/5,6 ⁸	CFS-C P 50/1.5"	EI 120-U/U
The results of 2.4.5.1 are also valid for PVC-C pipes according to EN 1566-1 ³ and PVC-U pipes according to EN 1329-1 ^{Error!} Bookmark not defined. and EN 1453-1 ^{Error! Bookmark not defined.}			

⁸ Interpolation of minimum wall thickness between 1,5 mm for diameter 20 mm and 2,4 mm for diameter 50 mm, interpolation of maximum wall thickness between 2,2 mm for diameter 20 mm and 5,6 mm for diameter 50 mm for pipe diameters in between.

ANNEX 3: INSTALLATION OF THE PRODUCT AND ANCILLARY PRODUCT(S)

The arrangement and installation of Hilti Firestop Collar CFS-C P shall be done in accordance with the details given below and in Annex 2 for the penetration seal(s).

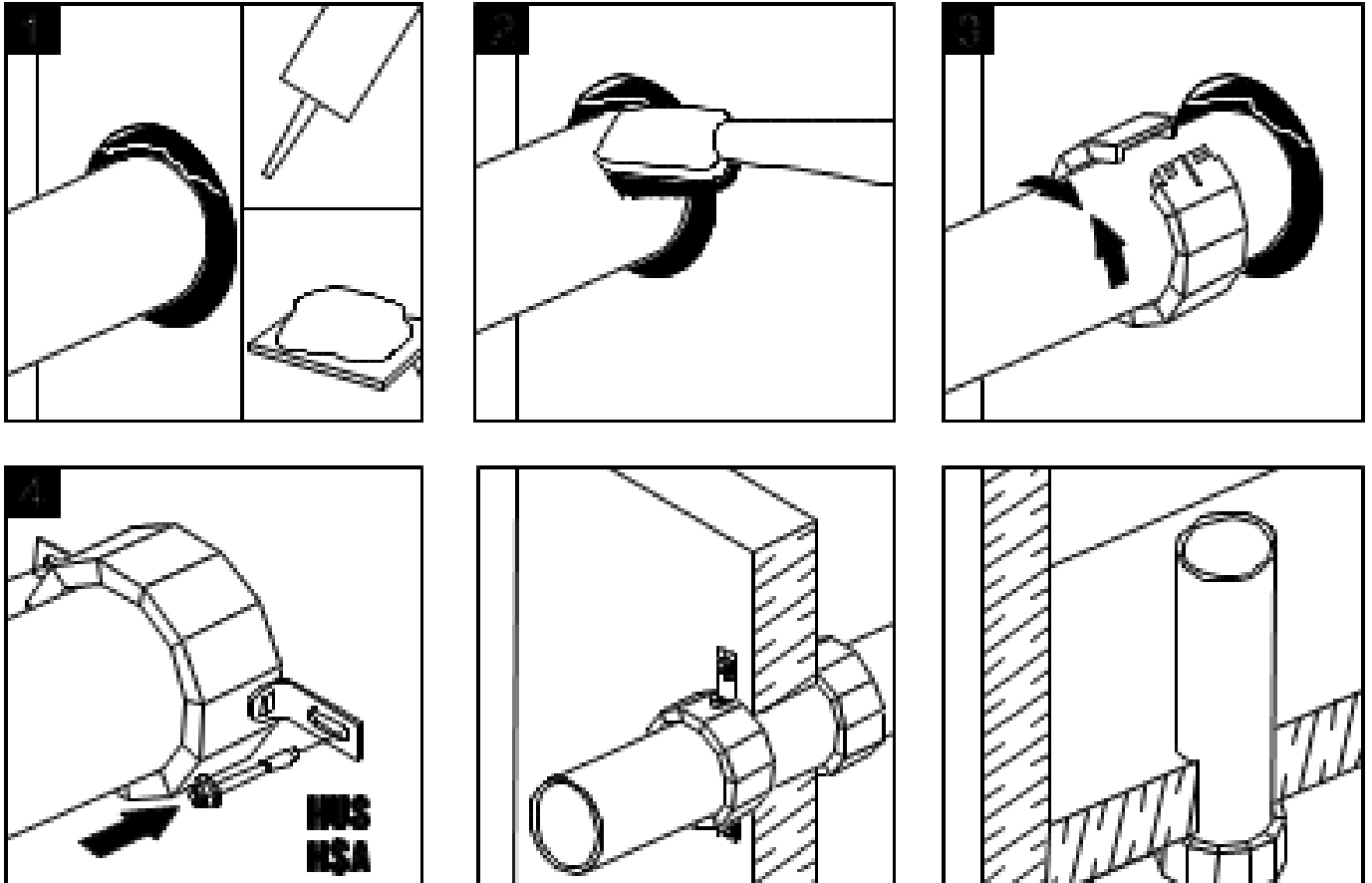

ANNEX 4: ABBREVIATIONS AND REFERENCE DOCUMENTS

4.1 Abbreviations used in drawings

Abbreviation	Description
A ₁	Hilti Firestop Collar CFS-C P
A ₂	Annular gap seal with Hilti Firestop Acrylic Sealant CFS-S ACR
A ₃	Annular gap seal with gypsum plaster or cementitious mortar
B	Backfilling material (mineral wool)
C	Plastic Pipe
C ₁	Sound decoupling
D	Pipe insulation
d _c	Pipe diameter (nominal outside diameter)
E	Building element (wall, floor)
F	Fixing of the collar
s ₁	Minimum distance between single penetration seals
t _{A2}	Thickness of Hilti Firestop Acrylic Sealant CFS-S ACR
t _c	Pipe wall thickness
t _D	Insulation thickness
t _E	Thickness of the building element
L _D	Length of Insulation

4.2 References to standards mentioned in the UKTA:

EN 1026	Windows and doors – Air permeability – Test method
EN 1329-1	Plastics piping systems for soil and waste discharge (low and high temperature) within the building structure - Unplasticized poly(vinyl chloride) (PVC-U)
EN 1366-3	Fire resistance tests for service installations - Part 3: Penetration seals
EN 1451-1	Plastics piping systems for soil and waste discharge (low and high temperature) within the building structure - Polypropylene (PP) – Part 1: Specifications for pipes, fittings and the system
EN 1453-1	Plastics piping systems with structured-wall pipes for soil and waste discharge (low and high temperature) inside buildings - Unplasticized poly(vinyl chloride) (PVC-U)
EN 1519-1	Plastics piping systems for soil and waste discharge (low and high temperature) within the building structure - Polyethylene (PE) - Part 1: Specifications for pipes, fittings and the system
EN 1566-1	Plastics piping systems for soil and waste discharge (low and high temperature) within the building structure - Chlorinated poly(vinyl chloride) (PVC-C) - Part 1: Specifications for pipes, fittings and the system
EN 12201-2	Plastics piping systems for water supply, and for drainage and sewerage under pressure - Polyethylene (PE) - Part 2: Pipes
EN 12666-1	Plastics piping systems for non-pressure underground drainage and sewerage – Polyethylene (PE) – Part 1: Specifications for pipes, fittings and the system
EN 13501	Fire classification of construction products and building elements – Part 1: Classification using test data from reaction to fire tests Part 2: Classification using test data from fire resistance tests, excluding ventilation services
EN ISO 140-3	Acoustics – Measurement of sound insulation in buildings and of building elements – Part 3: Laboratory measurements of airborne sound insulation of building elements ⁹
EN ISO 717-1	Acoustics – Rating of sound insulation of buildings and of building elements – Part 1: Airborne sound insulation

⁹ In September 2010 substituted by the EN ISO 10140 series
0843-UKTA-22/0043 of 31/03/2023 – Page 40 of 41

EN ISO 1519	Paints and varnishes – Bend test (cylindrical mandrel)
EN ISO 1452	Plastics piping systems for water supply and for buried and above-ground drainage and sewerage under pressure - Unplasticized poly(vinyl chloride) (PVC-U) ¹⁰
EN ISO 15493	Plastics piping systems for industrial applications - Acrylonitrile-butadiene-styrene (ABS), unplasticized poly(vinyl chloride) (PVC-U) and chlorinated poly(vinyl chloride) (PVC-C) - Specifications for components and the system; Metric series
EN ISO 15494	Plastics piping systems for industrial applications - Polybutene (PB), polyethylene (PE) and polypropylene (PP) - Specifications for components and the system; Metric series
EN ISO 15874	Plastics piping systems for hot and cold water installations - Polypropylene (PP)
EN ISO 20140-10	Acoustics – Measurements of sound insulation in buildings and of building elements – Part 10: Laboratory measurement of airborne sound insulation of small building elements ⁹

4.3 Other reference documents

EOTA TR 001	Determination of impact resistance of panels and panel assemblies
EOTA TR 024	Characterisation, Aspects of Durability and Factory Production Control for Reactive Materials, Components and Products

¹⁰ Successor of EN 1452 since December 2009