

X-QT Frame cramp

Product Data

X-QT ___ CR 16-4.5 P8THP

Fastening tool **DX 460-F8**

Cartridges:
**6,8/11M,
Red or Black**

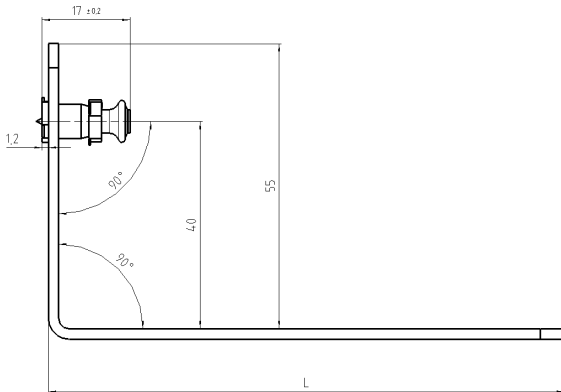

Piston: X-460-P8
Fastener Guide: X-460-F8

Specification

Cramp: stainless steel 1.4301 (X5CrNi1810) according to EN 10088-2
corrosion resistance: A2 or AISI 304
thickness: 2.0 mm for X-QT 100/125/150/175/200
2.3 mm for X-QT 225/250

Fastener: stainless steel CR 500, zinc plated
corrosion resistance: A4 or AISI 316
diameter: 4.5 mm, shank length 16 mm

Washers: plastic (polyethylene)

Application and intended use

Shear connection of the inner leaf of a cavity wall to the structural steel column.

Condition: The density of wall ties connecting the inner and the outer leaf according to BS 5628-1 need to be observed (e.g. 2.5 ties/m² in case both leaves are thicker than 90 mm).

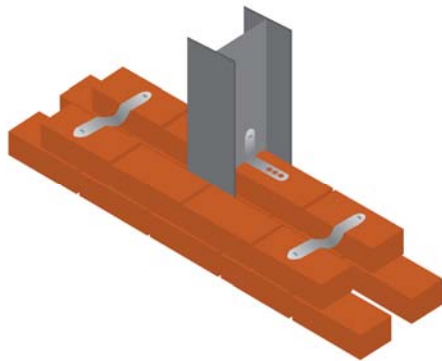

Standard shear use of X-QT frame Cramp

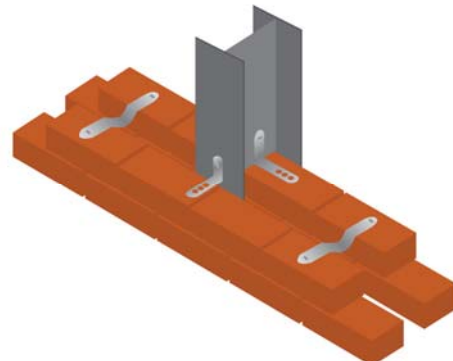

Acceptable use of X-QT Frame Cramp in tension

Standard Quicktie

Designation	Item No	Box Contents	Tool
X-QT100 CR 16-4.5 P8THP	361734	100	DX 460-F8
X-QT125 CR 16-4.5 P8THP	361735	100	DX 460-F8
X-QT150 CR 16-4.5 P8THP	361736	100	DX 460-F8
X-QT175 CR 16-4.5 P8THP	361737	100	DX 460-F8
X-QT200 CR 16-4.5 P8THP	361738	100	DX 460-F8
X-QT225 CR 16-4.5 P8THP	361739	100	DX 460-F8
X-QT250 CR 16-4.5 P8THP	361740	100	DX 460-F8

Recommended loads

Connection between X-QT and structural steel

X-QT	V_{rec} [kN]	N_{rec} [kN]
X-QT 100/125/150/175/200	2.0	0.06
X-QT 225/250	2.0	0.09

V_{rec} [kN] ... recommended shear load
 N_{rec} [kN] ... recommended tension load

Note on N_{rec} : N_{rec} is based on the serviceability criterion of an elastic deformation of 0.5 mm.

Design conditions:

- Redundancy (multiple fastening) must be provided.
- Valid for predominantly static loading (wind is considered as predominantly static).
- Anchorage of the cramp within the masonry needs to comply with recognized provisions.

Application limit and cartridge recommendation

Application limit

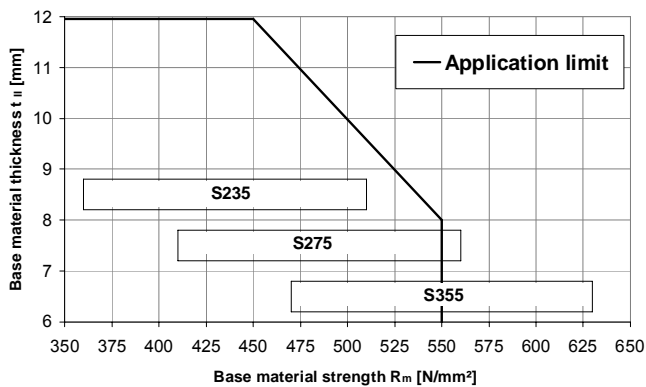

Base material specification:
 Non-alloy structural steel acc. to EN 10025-2.
 Range of base material thickness t_{II} :
 $6.0 \text{ mm} \leq t_{II} \leq 12.0 \text{ mm}$

Cartridge recommendation

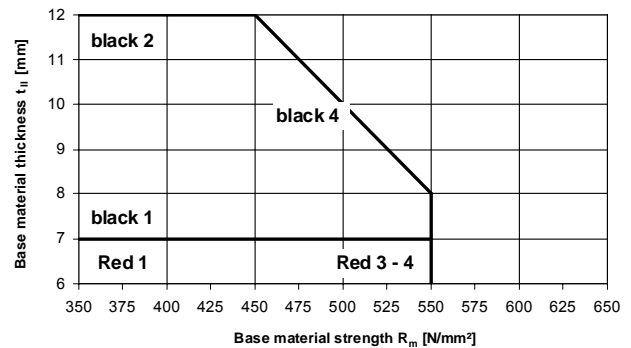

Cartridges: 6.8/11M black or red

Red: $6.0 \text{ mm} \leq t_{II} \leq 7.0 \text{ mm}$

Black: $t_{II} > 7.0 \text{ mm}$

The numbers in the chart refer to the recommended tool settings. In case the actual strength of the base material is unknown, start with the setting for low strength steel (Red 1 or black 1 and 2, respectively).

If necessary, adjust tool energy setting in order to achieve consistent compliance with the required nail head standoff.

Fastening Quality Assurance

Fastening inspection

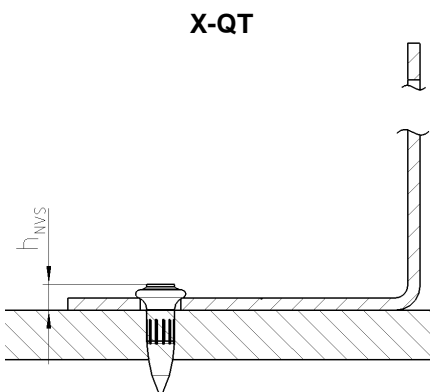

$h_{NVS} = 3.5 \text{ to } 5.5 \text{ mm}$



The photograph gives a visual impression of a correctly driven pin.

h_{NVS} ... Nail head standoff = Distance from top of the driven pin to the top surface of the base material.