



# X-FCM-R NG NARROW GRATING FASTENER DISC (STAINLESS STEEL)

Data Sheet

[English](#)

[Deutsch](#)

[Español](#)

[Français](#)

12.2023





# X-FCM-R NG NARROW GRATING FASTENER DISC (STAINLESS STEEL)

Data Sheet

[English](#)

12.2023

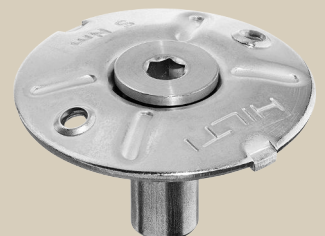

# CONTENTS

<b>1</b>	<b>Product info</b>	<b>2</b>
1.1	Product description	2
<b>2</b>	<b>Fastening system</b>	<b>3</b>
<b>3</b>	<b>Application conditions</b>	<b>3</b>
3.1	Applications	3
3.2	Base materials	3
3.3	Load conditions	4
3.4	Environmental conditions	4
<b>4</b>	<b>Approvals and certificates</b>	<b>4</b>
<b>5</b>	<b>Product data</b>	<b>5</b>
5.1	Dimensions	5
5.2	Material properties for stainless steel parts	5
5.3	Material properties for plastic parts	6
<b>6</b>	<b>Application requirements</b>	<b>6</b>
6.1	Grating material properties	6
6.2	Fastener application ranges	6
6.3	Grating element recommendation	7
6.4	Grating element recommendation for use with Threaded Stud Extension X-SEA	7
<b>7</b>	<b>Performance data</b>	<b>8</b>
7.1	Recommended loads	8
7.2	Calculation method for design resistance	8
<b>8</b>	<b>Installation recommendation</b>	<b>9</b>
8.1	Tightening tool recommendation	9
<b>9</b>	<b>Ordering information</b>	<b>10</b>
9.1	Item no. and description	10

# 1 PRODUCT INFO

## 1.1 Product description

Designation	Features
<p data-bbox="355 548 478 577">X-FCM-R NG</p> 	<ul data-bbox="630 548 1468 694" style="list-style-type: none"><li>• Approvals and certificates – technical data, test reports and approvals available</li><li>• Durable hold – locking tabs on the disc help to prevent loosening or spinning</li><li>• Labor-saving grating installation – fewer steps than traditional grating clamps and welding.</li><li>• No surface rework needed – when fastening grating to steel with S-BT and X-BT threaded studs</li><li>• Reduce trip hazards – non-slip surface and minimized protrusion on walkway gratings when correctly installed</li></ul>

## 2 FASTENING SYSTEM

<b>Fastener</b>	S-BT-GR M8/7 SN 6 HL	S-BT-GR M8/7 SN 6 HL AL	X-BT-GR M8/7 SN 8
<b>Base materials</b>	Steel	Aluminium	Steel
X-FCM-R NG	■	■	■

■ Recommended for combination

■ Suitable for combination

## 3 APPLICATION CONDITIONS

### 3.1 Applications

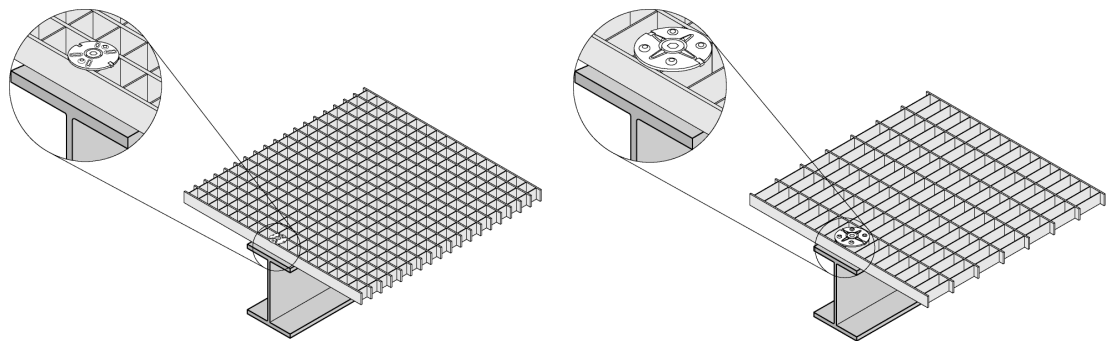

Securing square grating

Securing rectangular grating

### 3.2 Base materials

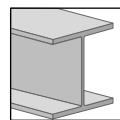

Steel

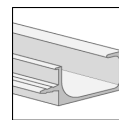

Aluminium

### 3.3 Load conditions



Static/quasi-static

### 3.4 Environmental conditions

X-FCM-R NG combined with S-BT-GR M8/7 SN 6 HL, S-BT-GR M8/7 SN 6 HL AL

Dry indoor	Indoor environments with temporary condensation	Outdoor, rural or urban environment with low pollution	Outdoor, rural or urban environment with moderate concentration of pollutants and/or salt from sea water	Coastal areas	Outdoor, areas with heavy industrial pollution	Close proximity to roadways treated with de-icing salts
■	■	■	■	■	■	■

- Suitable for corrosion prevention
- Requires expert evaluation

For more details, please refer to the [Hilti Corrosion Handbook](#)

## 4 APPROVALS AND CERTIFICATES

Authority	Approval/ certificate no	Date of issue
Bureau Veritas (BV)	BV 71291/A0 BV	06/07/2023
Det Norske Veritas (DNV)	TAS00001UJ Rev. 4	08/22/2023

- Information presented in this product data sheet is based on Hilti Technical Data.
- For the specific application please refer to the corresponding approval/certificate.

## 5 PRODUCT DATA

### 5.1 Dimensions

X-FCM-R NG

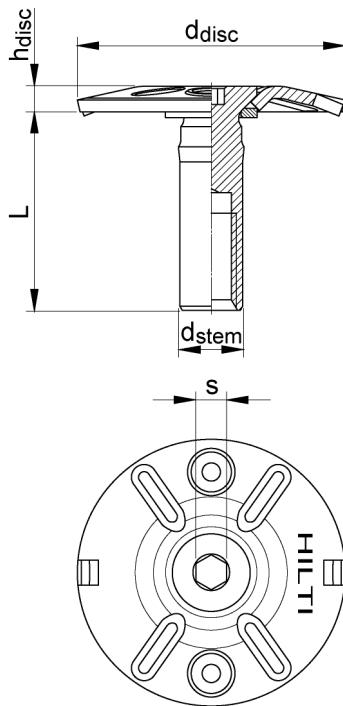

Designation	Length L [mm]	Stem diameter $d_{\text{stem}}$ [mm]	Disc diameter $d_{\text{disc}}$ [mm]	Disc height $h_{\text{disc}}$ [mm]	Hex width s [mm]
X-FCM-R NG 23/28	18	10.3	44	4	5
X-FCM-R NG 28/33	23	10.3	44	4	5
X-FCM-R NG 32/37	27	10.3	44	4	5
X-FCM-R NG 38/43	33	10.3	44	4	5
X-FCM-R NG 48/53	43	10.3	44	4	5

### 5.2 Material properties for stainless steel parts

Designation	Element	Material	Standard	Corrosion resistance class
X-FCM-R NG	Disc, threaded stem	1.4404	EN 10088	CRC III



• Corrosion resistance class according to EN 1993-1-4

### 5.3 Material properties for plastic parts

Designation	Element	Material	Color
X-FCM-R NG	Absorber O-Ring	Polyurethane (PUR)	Black

## 6 APPLICATION REQUIREMENTS

### 6.1 Grating material properties

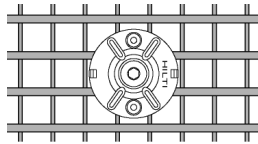

Grating type	Square
Clear bar spacing $w_{\text{bearing bar}}$ [mm]	13–22
Clear cross bar spacing $w_{\text{cross bar}}$ [mm]	13–22
Grating height $h_G$ [mm]	23–53
Grating height $h_G$ with X-SEA [mm]	53–83

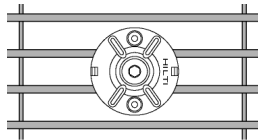

Grating type	Rectangular
Clear bar spacing $w_{\text{bearing bar}}$ [mm]	13–22
Grating height $h_G$ [mm]	23–53
Grating height $h_G$ with X-SEA [mm]	53–83

### 6.2 Fastener application ranges



- Application areas are provided in the corresponding Product Data Sheet(s) for fasteners.



### 6.3 Grating element recommendation

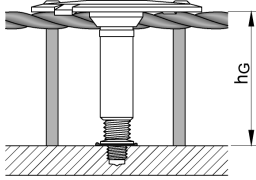

Designation	Grating material	Grating type	Grating height $h_G$ [mm]
X-FCM-R NG 23/28	Reinforced fiberglass, Stainless steel	Rectangular, Square	23-28
X-FCM-R NG 28/33			28-33
X-FCM-R NG 32/37			32-37
X-FCM-R NG 38/43			38-43
X-FCM-R NG 48/53			48-53

### 6.4 Grating element recommendation for use with Threaded Stud Extension X-SEA

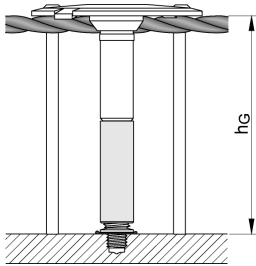

Designation	Grating material	Grating type	Grating height $h_G$ [mm]
X-FCM-R NG 23/28	Reinforced fiberglass, Stainless steel	Rectangular, Square	53-58
X-FCM-R NG 28/33			58-63
X-FCM-R NG 32/37			62-67
X-FCM-R NG 38/43			68-73
X-FCM-R NG 48/53			78-83

## 7 PERFORMANCE DATA

### 7.1 Recommended loads

Designation	Grating type	Clear bar spacing	Base material thickness	Tension load
		$w_{\text{bearing bar}}$ [mm]	$t_{II}$ [mm]	$N_{\text{rec}}$ [kN]
X-FCM-R NG combined with S-BT-GR M8/7 SN 6 HL	Square	13	3 - <5	2.3
		18		2.3
		22		2.3
		13	≥5	3.6
		18		3.6
		22		2.7
	Rectangular	13	3 - <5	2.3
		18		2.3
		22	≥5	2.1
		13		3.6
18	3.6			
22	2.1			

Designation	Grating type	Clear bar spacing	Base material thickness	Tension load
		$w_{\text{bearing bar}}$ [mm]	$t_{II}$ [mm]	$N_{\text{rec}}$ [kN]
X-FCM-R NG combined with S-BT-GR M8/7 SN 6 HL AL	Square	13	≥5	2.1
		18		2.1
		22		2.1
	Rectangular	13	≥5	2.1
		18		2.1
		22		2.1

- i**
- Not suitable for explicit shear load design, e.g. diaphragms.
  - Shear resistance by friction is depending on surface characteristics.
  - Small unexpected shear loads can be accommodated without damage.
  - Shear loads up to 0.3 kN will not result in permanent deformation.

### 7.2 Calculation method for design resistance

Load type	Equation	Partial safety factor for actions $\gamma_f$
Tension Load	$N_{Rd} = N_{\text{rec}} \cdot \gamma_f$	1.4
Shear Load	$V_{Rd} = V_{\text{rec}} \cdot \gamma_f$	1.4

## 8 INSTALLATION RECOMMENDATION

### 8.1 Tightening tool recommendation

Designation	Base materials	Base material thickness	Tightening torque	Tool type	Clutch type (stop detection)	Tool power level
		$t_{II}$ [mm]	$T_{rec}$ [Nm]			Gear / Clutch
X-FCM-R NG combined with S-BT-GR M8/7 SN 6 HL	Steel	$\geq 3$	8	Calibrated torque wrench		
				X-BT 1/4" - 8 Nm		
				SBT 4-A22	TRC	1 / 7
				SBT 6-22	ESC (SJ)	1 / 7
				SF 4-A22	TRC	1 / 8
				SF 6-A22	ESC (SJ)	1 / 7
				SF 6H-A22	ESC (SJ)	1 / 7
				SFC 22-A	TRC	1 / 5

Designation	Base materials	Base material thickness	Tightening torque	Tool type	Clutch type (stop detection)	Tool power level
		$t_{II}$ [mm]	$T_{rec}$ [Nm]			Gear / Clutch
X-FCM-R NG combined with S-BT-GR M8/7 SN 6 HL AL	Aluminium	$\geq 5$	8	Calibrated torque wrench		
				X-BT 1/4" - 8 Nm		
				SBT 4-A22	TRC	1 / 7
				SBT 6-22	ESC (SJ)	1 / 7
				SF 4-A22	TRC	1 / 8
				SF 6-A22	ESC (SJ)	1 / 7
				SF 6H-A22	ESC (SJ)	1 / 7
				SFC 22-A	TRC	1 / 5



- Electronic slip clutch (ESC): ESC has 2 stop detections, Soft Joint (SJ) and Hard Joint (HJ) . Hard joint detection is activated due to drop in speed (fast stop) and can lead to a torque spike.
- Torque release coupling (TRC): Achievable torque can change over time due to clutch wear.

## 9 ORDERING INFORMATION

### 9.1 Item no. and description

Designation	Item number	Description
X-FCM-R NG 23/28	2351685	X-FCM-R NG Narrow grating fastener disc (stainless steel)
X-FCM-R NG 28/33	2279757	
X-FCM-R NG 32/37	2279758	
X-FCM-R NG 38/43	2279759	
X-FCM-R NG 48/53	2279752	
S-BT-GR M8/7 SN 6 HL	2345767	S-BT-GR HL Threaded stud
S-BT-GR M8/7 SN 6 HL AL	2350548	S-BT-GR HL AL Threaded stud



Hilti Aktiengesellschaft  
9494 Schaan, Liechtenstein  
P +423-234 2965

[www.facebook.com/hiltigroup](https://www.facebook.com/hiltigroup)  
[www.hilti.group](https://www.hilti.group)



# X-FCM-R NG GITTERROST- BEFESTIGUNGS- TELLER (EDELSTAHL)

Datenblatt

[Deutsch](#)

12.2023

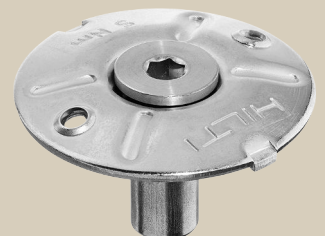

# INHALTSVERZEICHNIS

<b>1</b>	<b>Produktinformation</b>	<b>2</b>
1.1	Produktbeschreibung	2
<b>2</b>	<b>Befestigungssystem</b>	<b>3</b>
<b>3</b>	<b>Anwendungsbedingungen</b>	<b>3</b>
3.1	Anwendungen	3
3.2	Untergrundmaterial	3
3.3	Lastbedingungen	4
3.4	Umgebungsbedingungen	4
<b>4</b>	<b>Zulassungen und Zertifikate</b>	<b>4</b>
<b>5</b>	<b>Produktdaten</b>	<b>5</b>
5.1	Abmessungen	5
5.2	Materialspezifikation und Materialeigenschaften für Teile aus Edelstahl	6
5.3	Materialeigenschaften für Kunststoffteile	6
<b>6</b>	<b>Anwendungsbedingungen</b>	<b>6</b>
6.1	Materialeigenschaften von Gitterrosten	6
6.2	Anwendungsbereiche der Befestigungselemente	7
6.3	Empfehlung für Gitterrostbefestiger	7
6.4	Empfehlung für Gitterrostbefestiger zur Verwendung mit Gewindebolzen-Verlängerung X-SEA	7
<b>7</b>	<b>Leistungsdaten</b>	<b>8</b>
7.1	Empfohlene Lasten	8
7.2	Berechnungsmethode für Bemessungswiderstand	8
<b>8</b>	<b>Montageempfehlung</b>	<b>9</b>
8.1	Empfehlung für Anziehwerkzeuge	9
<b>9</b>	<b>Bestellinformation</b>	<b>10</b>
9.1	Artikel-Nr. und Beschreibung	10

# 1 PRODUKTINFORMATION

## 1.1 Produktbeschreibung

Bezeichnung	Besondere Eigenschaften
<p data-bbox="355 551 478 577">X-FCM-R NG</p> 	<ul style="list-style-type: none"> <li data-bbox="624 551 1487 600">• Keine Nachbearbeitung notwendig – bei Befestigung von Gitterrosten an Stahl mit S-BT und X-BT Gewindebolzen</li> <li data-bbox="624 600 1487 649">• Minimaler Installationsaufwand – weniger Schritte als mit herkömmlichen Gitterrostklammern und Schweißen.</li> <li data-bbox="624 649 1487 676">• Sicherer Halt – Sicherungslaschen am Teller helfen, ein Lösen oder Mitdrehen zu verhindern</li> <li data-bbox="624 676 1487 725">• Weniger Stolperfallen – rutschfreie Oberfläche und bei richtiger Montage minimaler Überstand über Laufroste</li> <li data-bbox="624 725 1487 752">• Zulassungen und Zertifikate – technische Daten, Prüfberichte und Zulassungen verfügbar</li> </ul>



## 2 BEFESTIGUNGSSYSTEM

<b>Befestigungselement</b>	S-BT-GR M8/7 SN 6 HL	S-BT-GR M8/7 SN 6 HL AL	X-BT-GR M8/7 SN 8
<b>Untergrundmaterial</b>	Stahl	Aluminium	Stahl
X-FCM-R NG	■	■	■

■ Empfohlen für Kombination

■ Geeignet für Kombination

## 3 ANWENDUNGSBEDINGUNGEN

### 3.1 Anwendungen

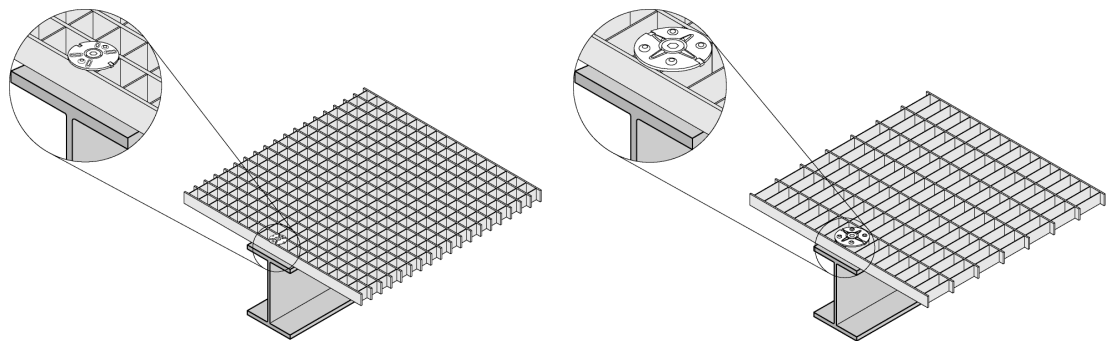

Sicherung quadratischer Gitterroste

Sicherung rechteckiger Gitterroste

### 3.2 Untergrundmaterial

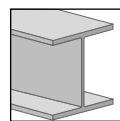

Stahl

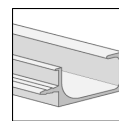

Aluminium

### 3.3 Lastbedingungen



Statisch/quasi-statisch

### 3.4 Umgebungsbedingungen

X-FCM-R NG in Verbindung mit S-BT-GR M8/7 SN 6 HL, S-BT-GR M8/7 SN 6 HL AL

Trockene Innenräume	Innenbereiche mit temporärer Kondensation	Außenbereich, ländliche oder städtische Umgebung mit geringer Umweltverschmutzung	Im Freien, in ländlicher oder städtischer Umgebung mit mäßiger Schadstoffkonzentration und/oder Salzen aus dem Meerwasser	Küstengebiete	Außenbereich mit hoher industrieller Schadstoffkonzentration	Nähe zu mit Streusalz behandelten Straßen
■	■	■	■	■	■	■

- Geeignet für den Korrosionsschutz
- Erfordert Expertenbewertung

• Weitere Einzelheiten entnehmen Sie bitte dem [Hilti Corrosion Handbook](#)

## 4 ZULASSUNGEN UND ZERTIFIKATE

Behörde	Zulassungs-/Zertifikatsnummer	Ausgabedatum
Bureau Veritas (BV)	BV 71291/A0 BV	07.06.2023
Det Norske Veritas (DNV)	TAS00001UJ Rev. 4	22.08.2023

- Die in diesem Produktdatenblatt enthaltenen Informationen basieren auf den technischen Daten von Hilti.  
• Für die spezifische Anwendung wird auf die entsprechende Zulassung/Bescheinigung verwiesen.

## 5 PRODUKTDATEN

### 5.1 Abmessungen

X-FCM-R NG

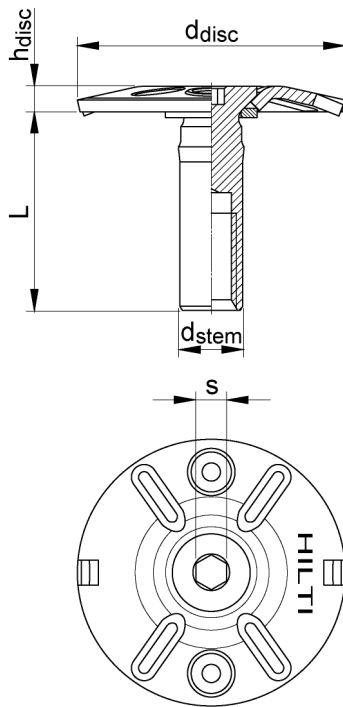

Bezeichnung	Länge	Buchsendurchmesser	Tellerdurchmesser	Tellerhöhe	Inbus Größe
	L [mm]	d <sub>stem</sub> [mm]	d <sub>disc</sub> [mm]	h <sub>disc</sub> [mm]	s [mm]
X-FCM-R NG 23/28	18	10,3	44	4	5
X-FCM-R NG 28/33	23	10,3	44	4	5
X-FCM-R NG 32/37	27	10,3	44	4	5
X-FCM-R NG 38/43	33	10,3	44	4	5
X-FCM-R NG 48/53	43	10,3	44	4	5

## 5.2 Materialspezifikation und Materialeigenschaften für Teile aus Edelstahl

Bezeichnung	Element	Material	Standard	Korrosionsbeständigkeitsklasse
X-FCM-R NG	Scheibe, Gewindeschaft	1.4404	EN 10088	CRC III

• Korrosionsbeständigkeit nach EN 1993-1-4

## 5.3 Materialeigenschaften für Kunststoffteile

Bezeichnung	Element	Material	Farbe
X-FCM-R NG	Dämpfer O-Ring	Polyurethan (PUR)	Schwarz

# 6 ANWENDUNGSBEDINGUNGEN

## 6.1 Materialeigenschaften von Gitterrosten

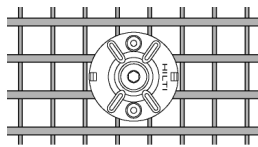

Gitterrost	Quadratisch
Lichter Stababstand $w_{\text{bearing bar}}$ [mm]	13 – 22
Lichter Stababstand Querstäbe $w_{\text{cross bar}}$ [mm]	13 – 22
Gitterrosthöhe $h_G$ [mm]	23 – 53
Gitterrosthöhe $h_G$ mit X-SEA [mm]	53 – 83

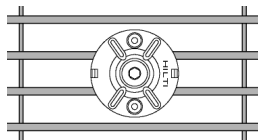

Gitterrost	Rechteckig
Lichter Stababstand $w_{\text{bearing bar}}$ [mm]	13 – 22
Gitterrosthöhe $h_G$ [mm]	23 – 53
Gitterrosthöhe $h_G$ mit X-SEA [mm]	53 – 83

## 6.2 Anwendungsbereiche der Befestigungselemente

- i** • Die Anwendungsbereiche sind in den entsprechenden Produktdatenblättern für Befestigungselemente angegeben.

## 6.3 Empfehlung für Gitterrostbefestiger

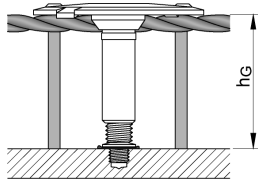

Bezeichnung	Gitterrostmaterial	Gitterrostart	Gitterrosthöhe $h_G$ [mm]
X-FCM-R NG 23/28	Edelstahl, Glasfaserverstärkt	Quadratisch, Rechteckig	23–28
X-FCM-R NG 28/33			28–33
X-FCM-R NG 32/37			32–37
X-FCM-R NG 38/43			38–43
X-FCM-R NG 48/53			48–53

## 6.4 Empfehlung für Gitterrostbefestiger zur Verwendung mit Gewindebolzen-Verlängerung X-SEA

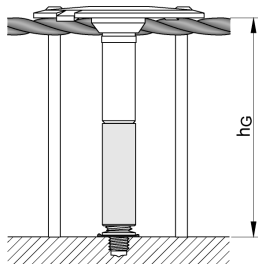

Bezeichnung	Gitterrostmaterial	Gitterrostart	Gitterrosthöhe $h_G$ [mm]
X-FCM-R NG 23/28	Edelstahl, Glasfaserverstärkt	Quadratisch, Rechteckig	53–58
X-FCM-R NG 28/33			58–63
X-FCM-R NG 32/37			62–67
X-FCM-R NG 38/43			68–73
X-FCM-R NG 48/53			78–83

## 7 LEISTUNGSDATEN

### 7.1 Empfohlene Lasten

Bezeichnung	Gitterrostart	Lichter Stababstand	Untergrundmaterialdicke	Zuglast
		$w_{\text{bearing bar}}$ [mm]	$t_{II}$ [mm]	$N_{\text{rec}}$ [kN]
X-FCM-R NG in Verbindung mit S-BT-GR M8/7 SN 6 HL	Rechteckig	13	3 - <5	2,3
		18		2,3
		22		2,1
		13	≥5	3,6
		18		3,6
		22		2,1
	Quadratisch	13	3 - <5	2,3
		18		2,3
		22		2,3
		13	≥5	3,6
		18		3,6
		22		2,7

Bezeichnung	Gitterrostart	Lichter Stababstand	Untergrundmaterialdicke	Zuglast
		$w_{\text{bearing bar}}$ [mm]	$t_{II}$ [mm]	$N_{\text{rec}}$ [kN]
X-FCM-R NG in Verbindung mit S-BT-GR M8/7 SN 6 HL AL	Rechteckig	13	≥5	2,1
		18		2,1
		22		2,1
	Quadratisch	13		2,1
		18		2,1
		22		2,1



- Nicht geeignet für Konstruktionen mit klaren Querkraftwirkungen, z. B. Membranen.
- Die Querkrafttragfähigkeit hängt von den Oberflächeneigenschaften ab.
- Kleine unerwartete Scherkräfte können ohne Schaden aufgenommen werden.
- Querkräfte bis zu 0,3 kN führen nicht zu bleibenden Verformungen.

### 7.2 Berechnungsmethode für Bemessungswiderstand

Belastungsart	Gleichung	Teilsicherheitsfaktor für Einwirkungen $\gamma_f$
Zuglast	$N_{Rd} = N_{rec} \cdot \gamma_f$	1,4
Querlast	$V_{Rd} = V_{rec} \cdot \gamma_f$	1,4

## 8 MONTAGEEMPFEHLUNG

### 8.1 Empfehlung für Anziehwerkzeuge

Bezeichnung	Untergrundmaterial	Dicke des Untergrundmaterials	Anzugsdrehmoment	Gerätetyp	Kupplungsart (Stopp-Erkennung)	Werkzeugleistungsstufe
		$t_{II}$ [mm]	$T_{rec}$ [Nm]			
X-FCM-R NG in Verbindung mit S-BT-GR M8/7 SN 6 HL	Stahl	$\geq 3$	8	Calibrated torque wrench		
				X-BT 1/4" - 8 Nm		
				SBT 4-A22	TRC	1 / 7
				SBT 6-22	ESC (SJ)	1 / 7
				SF 4-A22	TRC	1 / 8
				SF 6-A22	ESC (SJ)	1 / 7
				SF 6H-A22	ESC (SJ)	1 / 7
				SFC 22-A	TRC	1 / 5

Bezeichnung	Untergrundmaterial	Dicke des Untergrundmaterials	Anzugsdrehmoment	Gerätetyp	Kupplungsart (Stopp-Erkennung)	Werkzeugleistungsstufe
		$t_{II}$ [mm]	$T_{rec}$ [Nm]			
X-FCM-R NG in Verbindung mit S-BT-GR M8/7 SN 6 HL AL	Aluminium	$\geq 5$	8	Calibrated torque wrench		
				X-BT 1/4" - 8 Nm		
				SBT 4-A22	TRC	1 / 7
				SBT 6-22	ESC (SJ)	1 / 7
				SF 4-A22	TRC	1 / 8
				SF 6-A22	ESC (SJ)	1 / 7
				SF 6H-A22	ESC (SJ)	1 / 7
				SFC 22-A	TRC	1 / 5



- Elektronische Rutschkupplung (ESC): Die ESC verfügt über 2 Stopp-Erkennungen, weicher Schraubabfall (SJ) und harter Schraubabfall (HJ). Die Erkennung des harten Schraubabfalls wird durch einen Geschwindigkeitsabfall (Schnellstopp) aktiviert und kann zu einer Drehmomentspitze führen.
- Drehmomentbegrenzer (TRC): Das erreichbare Drehmoment kann sich im Laufe der Zeit aufgrund von Kupplungsverschleiß ändern.

## 9 BESTELLINFORMATION

### 9.1 Artikel-Nr. und Beschreibung

Bezeichnung	Artikelnummer	Beschreibung
X-FCM-R NG 23/28	2351685	X-FCM-R NG Gitterrost-Befestigungsteller (Edelstahl)
X-FCM-R NG 28/33	2279757	
X-FCM-R NG 32/37	2279758	
X-FCM-R NG 38/43	2279759	
X-FCM-R NG 48/53	2279752	
S-BT-GR M8/7 SN 6 HL	2345767	S-BT-GR HL Gewindebolzen
S-BT-GR M8/7 SN 6 HL AL	2350548	S-BT-GR HL AL Gewindebolzen





Hilti Aktiengesellschaft  
9494 Schaan, Liechtenstein  
P +423-234 2965

[www.facebook.com/hiltigroup](https://www.facebook.com/hiltigroup)  
[www.hilti.group](https://www.hilti.group)



# X-FCM-R NG ESPIGA DE REJILLA INDUSTRIAL ESTRECHA (ACERO INOXIDABLE)

Hoja de datos

[Español](#)

12.2023



## ÍNDICE

<b>1</b>	<b>Información del producto</b>	<b>2</b>
1.1	Descripción del producto	2
<b>2</b>	<b>Sistema de fijación</b>	<b>3</b>
<b>3</b>	<b>Condiciones de aplicación</b>	<b>3</b>
3.1	Aplicaciones	3
3.2	Materiales base	3
3.3	Condiciones de carga	4
3.4	Condiciones ambientales	4
<b>4</b>	<b>Homologaciones y certificados</b>	<b>4</b>
<b>5</b>	<b>Datos del producto</b>	<b>5</b>
5.1	Dimensiones	5
5.2	Propiedades del material para piezas de acero inoxidable	5
5.3	Propiedades del material para piezas de plástico	6
<b>6</b>	<b>Requisitos de aplicación</b>	<b>6</b>
6.1	Propiedades de material de rejilla industrial	6
6.2	Rangos de aplicación de la fijación	6
6.3	Recomendación de elemento de rejilla industrial	7
6.4	Recomendación de elemento de rejilla industrial con extensión de pernos roscados X-SEA	7
<b>7</b>	<b>Datos de rendimiento</b>	<b>8</b>
7.1	Cargas recomendadas	8
7.2	Procedimiento de cálculo de la resistencia de diseño	8
<b>8</b>	<b>Recomendación de instalación</b>	<b>9</b>
8.1	Recomendación de herramientas de ajuste	9
<b>9</b>	<b>Información del pedido</b>	<b>10</b>
9.1	Nº. y descripción del artículo	10

# 1. INFORMACIÓN DEL PRODUCTO

## 1.1. Descripción del producto

Designación	Características
X-FCM-R NG 	<ul style="list-style-type: none"><li>• Ahorro de tiempo en la instalación de rejillas industriales: proceso que requiere menos pasos que los sistemas tradicionales de grapas y soldadura.</li><li>• Homologaciones y certificados: disponibilidad de datos técnicos, informes de ensayo y homologaciones</li><li>• No requiere rectificación de la superficie cuando la rejilla industrial se fija a acero con los pernos roscados X-BT y S-BT</li><li>• Reducción del riesgo de tropiezos: superficie antideslizante con protrusión mínima en rejillas industriales de pasarelas cuando la instalación se realiza correctamente</li><li>• Sujeción duradera: las pestañas de bloqueo de la espiga evitan el giro o el desprendimiento</li></ul>

## 2. SISTEMA DE FIJACIÓN

<b>Fijación</b>	S-BT-GR M8/7 SN 6 HL	S-BT-GR M8/7 SN 6 HL AL	X-BT-GR M8/7 SN 8
<b>Materiales base</b>	Acero	Aluminio	Acero
X-FCM-R NG	■	■	■

■ Recomendado para la combinación

■ Adecuado para la combinación

## 3. CONDICIONES DE APLICACIÓN

### 3.1. Aplicaciones

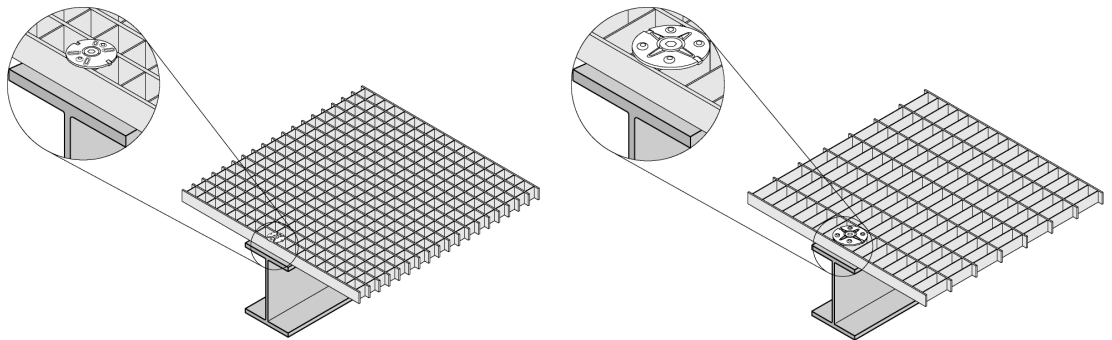

Fijación de rejilla industrial cuadrada

Fijación de rejilla industrial rectangular

### 3.2. Materiales base

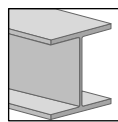

Acero

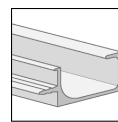

Aluminio

### 3.3. Condiciones de carga



Estática y cuasi estática

### 3.4. Condiciones ambientales

X-FCM-R NG combinado con S-BT-GR M8/7 SN 6 HL, S-BT-GR M8/7 SN 6 HL AL

Interiores secos	Entornos interiores con condensación temporal	Entornos exteriores, rurales o urbanos con poca contaminación	Entorno exterior, rural o urbano con una concentración moderada de contaminantes y/o sal del agua marina	Zonas de costa	Exterior, zonas con mucha contaminación industrial	Proximidad a calzadas tratadas con sales de deshielo
■	■	■	■	■	■	■

- Adecuado para la prevención de corrosión
- Requiere la evaluación de un especialista

Para obtener más información, consulte [Manual sobre corrosión de Hilti](#)

## 4. HOMOLOGACIONES Y CERTIFICADOS

Autoridad	N.º de homologación/certificado	Fecha de emisión
Bureau Veritas (BV)	BV 71291/A0 BV	06/07/2023
Det Norske Veritas (DNV)	TAS00001UJ Rev. 4	08/22/2023

- La información que se presenta en esta hoja de datos del producto se basa en los datos técnicos de Hilti.
- Para obtener información sobre aplicaciones específicas, consulte el certificado o la homologación correspondientes.

## 5. DATOS DEL PRODUCTO

### 5.1. Dimensiones

X-FCM-R NG

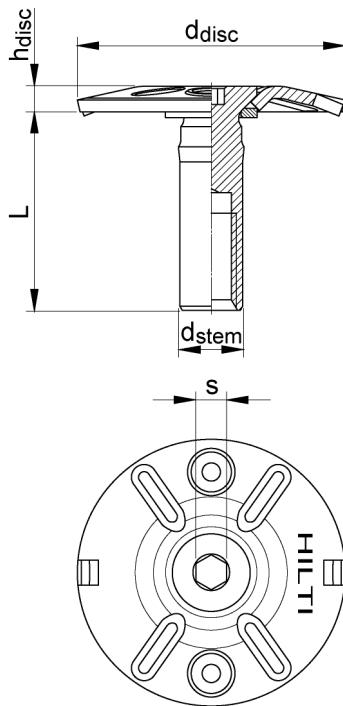

Designación	Longitud	Diámetro del vástago	Diámetro del disco	Altura del disco	Anchura hexagonal
	L [mm]	d <sub>stem</sub> [mm]	d <sub>disc</sub> [mm]	h <sub>disc</sub> [mm]	s [mm]
X-FCM-R NG 23/28	18	10,3	44	4	5
X-FCM-R NG 28/33	23	10,3	44	4	5
X-FCM-R NG 32/37	27	10,3	44	4	5
X-FCM-R NG 38/43	33	10,3	44	4	5
X-FCM-R NG 48/53	43	10,3	44	4	5

### 5.2. Propiedades del material para piezas de acero inoxidable

Designación	Elemento	Material	Standard	Clase de resistencia a la corrosión
X-FCM-R NG	Disco, vástago roscado	1.4404	EN 10088	CRC III



• Clase de resistencia a la corrosión conforme a la norma EN 1993-1-4

### 5.3. Propiedades del material para piezas de plástico

Designación	Elemento	Material	Color
X-FCM-R NG	Junta tórica de absorción	Poliuretano (PUR)	Negro

## 6. REQUISITOS DE APLICACIÓN

### 6.1. Propiedades de material de rejilla industrial

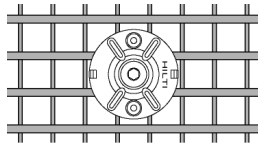

Tipo de rejilla industrial	Cuadrado
Separación entre barras $w_{\text{bearing bar}}$ [mm]	13–22
Separación entre barras transversales $w_{\text{cross bar}}$ [mm]	13–22
Altura de rejilla industrial $h_G$ [mm]	23–53
Altura de rejilla industrial $h_G$ con X-SEA [mm]	53–83

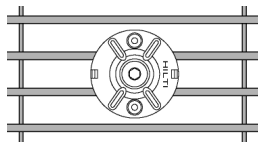

Tipo de rejilla industrial	Rectangular
Separación entre barras $w_{\text{bearing bar}}$ [mm]	13–22
Altura de rejilla industrial $h_G$ [mm]	23–53
Altura de rejilla industrial $h_G$ con X-SEA [mm]	53–83

### 6.2. Rangos de aplicación de la fijación

- Las áreas de aplicación se proporcionan en las hojas de datos de producto correspondientes para las fijaciones.



### 6.3. Recomendación de elemento de rejilla industrial

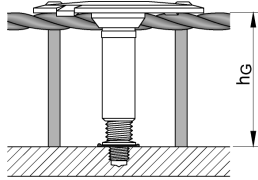

Designación	Material de rejilla industrial	Tipo de rejilla industrial	Altura de rejilla industrial $h_G$ [mm]
X-FCM-R NG 23/28	Acero inoxidable,	Cuadrado,	23-28
X-FCM-R NG 28/33	Fibra de vidrio reforzada	Rectangular	28-33
X-FCM-R NG 32/37			32-37
X-FCM-R NG 38/43			38-43
X-FCM-R NG 48/53			48-53

### 6.4. Recomendación de elemento de rejilla industrial con extensión de pernos roscados X-SEA

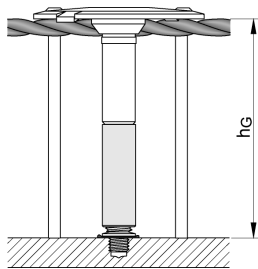

Designación	Material de rejilla industrial	Tipo de rejilla industrial	Altura de rejilla industrial $h_G$ [mm]
X-FCM-R NG 23/28	Acero inoxidable,	Cuadrado,	53-58
X-FCM-R NG 28/33	Fibra de vidrio reforzada	Rectangular	58-63
X-FCM-R NG 32/37			62-67
X-FCM-R NG 38/43			68-73
X-FCM-R NG 48/53			78-83

## 7. DATOS DE RENDIMIENTO

### 7.1. Cargas recomendadas

Designación	Tipo de rejilla industrial	Separación entre barras	Base material thickness	Carga de tensión
		$w_{\text{bearing bar}}$ [mm]	$t_{II}$ [mm]	$N_{\text{rec}}$ [kN]
X-FCM-R NG combinado con S-BT-GR M8/7 SN 6 HL	Rectangular	13	3 - <5	2,3
		18		2,3
		22		2,1
		13	≥5	3,6
		18		3,6
		22		2,1
	Cuadrado	13	3 - <5	2,3
		18		2,3
		22		2,3
		13	≥5	3,6
		18		3,6
		22		2,7

Designación	Tipo de rejilla industrial	Separación entre barras	Base material thickness	Carga de tensión
		$w_{\text{bearing bar}}$ [mm]	$t_{II}$ [mm]	$N_{\text{rec}}$ [kN]
X-FCM-R NG combinado con S-BT-GR M8/7 SN 6 HL AL	Rectangular	13	≥5	2,1
		18		2,1
		22		2,1
	Cuadrado	13		2,1
		18		2,1
		22		2,1

- i**
- No apto para diseños carga cortante explícita, como, por ejemplo, diafragmas.
  - La resistencia a cortante por fricción depende de las características de la superficie.
  - Tolerancia sin daños a cargas cortantes leves e inesperadas.
  - Las cargas cortantes de hasta 0,3 kN no provocarán deformación permanentemente.

### 7.2. Procedimiento de cálculo de la resistencia de diseño

Tipo de carga	Ecuación	Factor de seguridad parcial para acciones $\gamma_f$
Carga de tracción	$N_{Rd} = N_{\text{rec}} \cdot \gamma_f$	1,4
Carga cortante	$V_{Rd} = V_{\text{rec}} \cdot \gamma_f$	1,4

## 8. RECOMENDACIÓN DE INSTALACIÓN

### 8.1. Recomendación de herramientas de ajuste

Designación	Materiales base	Esesor del material base	Par de apriete	Tipo de herramienta	Tipo de embrague (detección de parada)	Nivel de potencia de la herramienta
		$t_{ij}$ [mm]	$T_{rec}$ [Nm]			Marcha / Embrague
X-FCM-R NG combinado con S-BT-GR M8/7 SN 6 HL	Acero	$\geq 3$	8	Llave dinámica calibrada		
				X-BT 1/4" - 8 Nm		
				SBT 4-A22	TRC	1 / 7
				SBT 6-22	ESC (SJ)	1 / 7
				SF 4-A22	TRC	1 / 8
				SF 6-A22	ESC (SJ)	1 / 7
				SF 6H-A22	ESC (SJ)	1 / 7
				SFC 22-A	TRC	1 / 5

Designación	Materiales base	Esesor del material base	Par de apriete	Tipo de herramienta	Tipo de embrague (detección de parada)	Nivel de potencia de la herramienta
		$t_{ij}$ [mm]	$T_{rec}$ [Nm]			Marcha / Embrague
X-FCM-R NG combinado con S-BT-GR M8/7 SN 6 HL AL	Aluminio	$\geq 5$	8	Llave dinámica calibrada		
				X-BT 1/4" - 8 Nm		
				SBT 4-A22	TRC	1 / 7
				SBT 6-22	ESC (SJ)	1 / 7
				SF 4-A22	TRC	1 / 8
				SF 6-A22	ESC (SJ)	1 / 7
				SF 6H-A22	ESC (SJ)	1 / 7
				SFC 22-A	TRC	1 / 5



- Embrague de seguridad electrónico (ESC): el sistema ESC cuenta con 2 detecciones, juntas blandas (SJ) y juntas duras (HJ). La detección de junta dura se activa con la caída de la velocidad (parada rápida) y puede provocar un pico de par.
- Par de apriete de acoplamiento (TRC): el par de apriete obtenido puede cambiar con el tiempo debido al desgaste del embrague.

## 9. INFORMACIÓN DEL PEDIDO

### 9.1. N°. y descripción del artículo

Designación	Número de elemento	Descripción
X-FCM-R NG 23/28	2351685	X-FCM-R NG Espiga de rejilla industrial estrecha (acero inoxidable)
X-FCM-R NG 28/33	2279757	
X-FCM-R NG 32/37	2279758	
X-FCM-R NG 38/43	2279759	
X-FCM-R NG 48/53	2279752	
S-BT-GR M8/7 SN 6 HL	2345767	Perno roscado S-BT-GR HL
S-BT-GR M8/7 SN 6 HL AL	2350548	Perno roscado S-BT-GR HL AL



Hilti Aktiengesellschaft  
9494 Schaan, Liechtenstein  
P +423-234 2965

[www.facebook.com/hiltigroup](https://www.facebook.com/hiltigroup)  
[www.hilti.group](https://www.hilti.group)



# X-FCM-R NG COUPELLE DE FIXATION POUR CAILLEBOTIS ÉTROITS (ACIER INOXYDABLE)

Fiche technique

[Français](#)

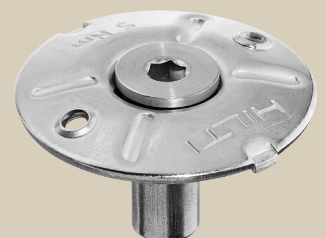

12.2023

## TABLE DES MATIÈRES

<b>1</b>	<b>Information produit</b>	<b>2</b>
1.1	Description du produit	2
<b>2</b>	<b>Système de fixation</b>	<b>3</b>
<b>3</b>	<b>Conditions d'application</b>	<b>3</b>
3.1	Applications	3
3.2	Matériau support	3
3.3	Conditions de charge	4
3.4	Conditions environnementales	4
<b>4</b>	<b>Homologations et certificats</b>	<b>4</b>
<b>5</b>	<b>Données produit</b>	<b>5</b>
5.1	Dimensions	5
5.2	Propriétés du matériau pour pièces en acier inoxydable	5
5.3	Propriétés du matériau pour pièces plastiques	6
<b>6</b>	<b>Exigences en matière d'application</b>	<b>6</b>
6.1	Propriétés du matériau de caillebotis	6
6.2	Plages d'applications de fixations	6
6.3	Élément de caillebotis recommandé	7
6.4	Élément de caillebotis recommandé avec l'extension de goujon fileté X-SEA	7
<b>7</b>	<b>Données de performance</b>	<b>8</b>
7.1	Charges recommandées	8
7.2	Méthode de calcul pour la résistance de conception	8
<b>8</b>	<b>Recommandation sur l'installation</b>	<b>9</b>
8.1	Recommandation sur l'outil de serrage	9
<b>9</b>	<b>Information de commande</b>	<b>10</b>
9.1	N° d'article et description	10

# 1 INFORMATION PRODUIT

## 1.1 Description du produit

Désignation	Caractéristiques
X-FCM-R NG	<ul style="list-style-type: none"><li>• Aucune retouche de surface nécessaire lors de la fixation de caillebotis sur l'acier avec des goujons filetés S-BT et X-BT</li><li>• Économie de main d'œuvre sur la pose de caillebotis - moins d'étapes qu'avec les cavaliers traditionnels et la soudure</li><li>• Homologations et certificats – données techniques, rapports d'essais et homologations disponibles</li><li>• Réduction du risque de trébuchement – surface antidérapante et saillie minimale sur les caillebotis de passerelle lorsqu'ils sont installés correctement</li><li>• Tenue durable - ergots de verrouillage sur la coupelle pour éviter le desserrage ou la rotation</li></ul>





## 2 SYSTÈME DE FIXATION

<b>Fixation</b>	S-BT-GR M8/7 SN 6 HL	S-BT-GR M8/7 SN 6 HL AL	X-BT-GR M8/7 SN 8
<b>Matériau support</b>	Acier	Aluminium	Acier
X-FCM-R NG	■	■	■

■ Recommandée pour combinaison

■ Adapté à une combinaison

## 3 CONDITIONS D'APPLICATION

### 3.1 Applications

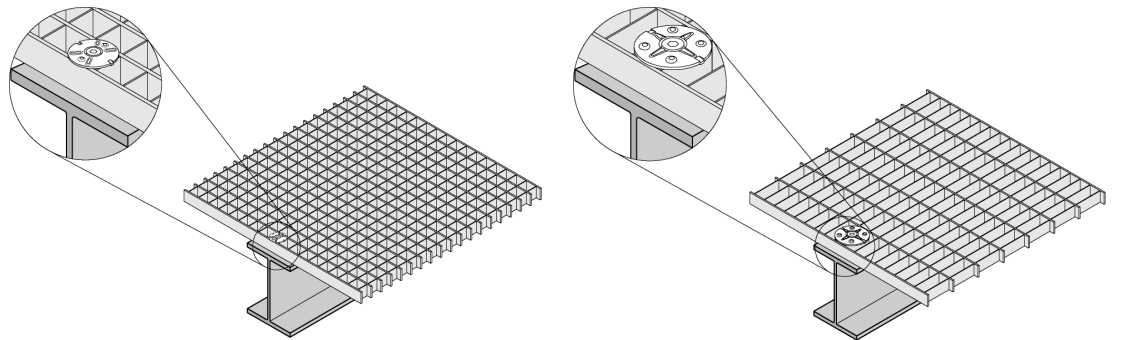

Fixation de caillebotis carré

Fixation de caillebotis rectangulaire

### 3.2 Matériau support

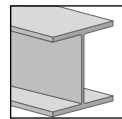

Acier

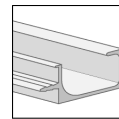

Aluminium

### 3.3 Conditions de charge



Statique/quasi statique

### 3.4 Conditions environnementales

X-FCM-R NG combiné à S-BT-GR M8/7 SN 6 HL, S-BT-GR M8/7 SN 6 HL AL

Intérieurs secs	Environnements intérieurs avec condensation temporaire	Environnement extérieur, rural ou urbain avec faible pollution	Environnement extérieur, rural ou urbain avec concentration modérée de polluants et/ou de sel d'eau de mer	Zones côtières	Milieu extérieur avec forte pollution industrielle	Étroite proximité avec des voies de circulation traitées avec des sels de dégivrage
■	■	■	■	■	■	■

- Adapté à la prévention de la corrosion
- Nécessite une évaluation par des spécialistes

• Pour plus de détails, reportez-vous au [manuel sur la corrosion Hilti](#)

## 4 HOMOLOGATIONS ET CERTIFICATS

Autorité	N° d'homologation/de certificat	Date d'émission
Bureau Veritas (BV)	BV 71291/A0 BV	07.06.2023
Det Norske Veritas (DNV)	TAS00001UJ Rev. 4	22.08.2023

- Les informations présentées dans cette fiche technique produit sont basées sur les données techniques Hilti.
- Pour l'application spécifique, veuillez consulter l'homologation/certificat correspondant.

## 5 DONNÉES PRODUIT

### 5.1 Dimensions

X-FCM-R NG

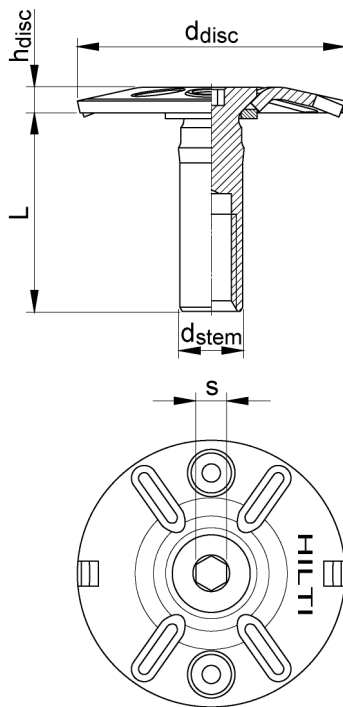

Désignation	Longueur	Diamètre du goujon	Diamètre du disque	Hauteur du disque	Largeur hex
	L [mm]	d <sub>stem</sub> [mm]	d <sub>disc</sub> [mm]	h <sub>disc</sub> [mm]	s [mm]
X-FCM-R NG 23/28	18	10,3	44	4	5
X-FCM-R NG 28/33	23	10,3	44	4	5
X-FCM-R NG 32/37	27	10,3	44	4	5
X-FCM-R NG 38/43	33	10,3	44	4	5
X-FCM-R NG 48/53	43	10,3	44	4	5

### 5.2 Propriétés du matériau pour pièces en acier inoxydable

Désignation	Élément	Matériau	Standard	Classe de résistance à la corrosion
X-FCM-R NG	Coupelle, goujon fileté	1.4404	EN 10088	CRC III

• Classe de résistance à la corrosion selon EN 1993-1-4

### 5.3 Propriétés du matériau pour pièces plastiques

Désignation	Élément	Matériau	Couleur
X-FCM-R NG	Joint torique d'absorbeur	Polyuréthane (PUR)	Noir

## 6 EXIGENCES EN MATIÈRE D'APPLICATION

### 6.1 Propriétés du matériau de caillebotis

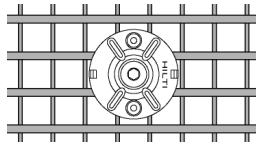

Type de caillebotis	Carré
Espacement de la barre dégagee $w_{\text{bearing bar}}$ [mm]	13-22
Espacement de la barre transversale $w_{\text{cross bar}}$ [mm]	13-22
Hauteur de caillebotis $h_G$ [mm]	23-53
Hauteur de caillebotis $h_G$ avec X-SEA [mm]	53-83

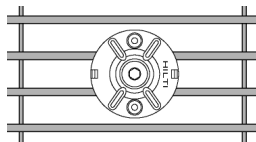

Type de caillebotis	Rectangulaire
Espacement de la barre dégagee $w_{\text{bearing bar}}$ [mm]	13-22
Hauteur de caillebotis $h_G$ [mm]	23-53
Hauteur de caillebotis $h_G$ avec X-SEA [mm]	53-83

### 6.2 Plages d'applications de fixations



- Les domaines d'application sont indiqués dans la ou les fiches techniques produits correspondants aux fixations.

### 6.3 Élément de caillebotis recommandé

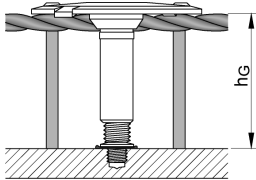

Désignation	Matériau de caillebotis	Type de caillebotis	Hauteur de caillebotis $h_G$ [mm]
X-FCM-R NG 23/28	Acier inoxydable, Fibre de verre renforcée	Carré, Rectangulaire	23-28
X-FCM-R NG 28/33			28-33
X-FCM-R NG 32/37			32-37
X-FCM-R NG 38/43			38-43
X-FCM-R NG 48/53			48-53

### 6.4 Élément de caillebotis recommandé avec l'extension de goujon fileté X-SEA

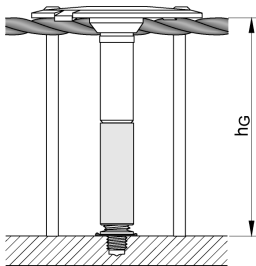

Désignation	Matériau de caillebotis	Type de caillebotis	Hauteur de caillebotis $h_G$ [mm]
X-FCM-R NG 23/28	Acier inoxydable, Fibre de verre renforcée	Carré, Rectangulaire	53-58
X-FCM-R NG 28/33			58-63
X-FCM-R NG 32/37			62-67
X-FCM-R NG 38/43			68-73
X-FCM-R NG 48/53			78-83

## 7 DONNÉES DE PERFORMANCE

### 7.1 Charges recommandées

Désignation	Type de caillebotis	Espacement de la barre dégagee	Épaisseur du matériau support	Charge de traction
		$w_{\text{bearing bar}}$ [mm]	$t_{II}$ [mm]	$N_{\text{rec}}$ [kN]
X-FCM-R NG combiné à S-BT-GR M8/7 SN 6 HL	Rectangulaire	13	3 - <5	2,3
		18		2,3
		22		2,1
		13	≥5	3,6
		18		3,6
		22		2,1
	Carré	13	3 - <5	2,3
		18		2,3
		22		2,3
		13	≥5	3,6
		18		3,6
		22		2,7

Désignation	Type de caillebotis	Espacement de la barre dégagee	Épaisseur du matériau support	Charge de traction
		$w_{\text{bearing bar}}$ [mm]	$t_{II}$ [mm]	$N_{\text{rec}}$ [kN]
X-FCM-R NG combiné à S-BT-GR M8/7 SN 6 HL AL	Rectangulaire	13	≥5	2,1
		18		2,1
		22		2,1
	Carré	13		2,1
		18		2,1
		22		2,1

- i**
- Ne convient pas à une conception avec charge de cisaillement explicite, p. ex. diaphragmes.
  - La résistance au cisaillement par frottement dépend des caractéristiques de la surface.
  - Les faibles charges de cisaillement inattendues peuvent être tolérées sans dommage.
  - Les charges de cisaillement jusqu'à 0,3 kN ne causent pas de déformation permanente.

### 7.2 Méthode de calcul pour la résistance de conception

Type de charge	Équation	Facteur partiel de sécurité pour actions $\gamma_f$
Charge de traction	$N_{Rd} = N_{rec} \cdot \gamma_f$	1,4
Charge de cisaillement	$V_{Rd} = V_{rec} \cdot \gamma_f$	1,4

## 8 RECOMMANDATION SUR L'INSTALLATION

### 8.1 Recommandation sur l'outil de serrage

Désignation	Matériau support	Épaisseur du matériau support	Couple de serrage	Type d'outil	Type d'embrayage (détection d'arrêt)	Niveau de puissance de l'outil
		$t_{II}$ [mm]	$T_{rec}$ [Nm]			Vitesse / Embrayage
X-FCM-R NG combiné à S-BT-GR M8/7 SN 6 HL	Acier	$\geq 3$	8	Calibrated torque wrench		
				X-BT 1/4" - 8 Nm		
				SBT 4-A22	TRC	1 / 7
				SBT 6-22	ESC (SJ)	1 / 7
				SF 4-A22	TRC	1 / 8
				SF 6-A22	ESC (SJ)	1 / 7
				SF 6H-A22	ESC (SJ)	1 / 7
				SFC 22-A	TRC	1 / 5

Désignation	Matériau support	Épaisseur du matériau support	Couple de serrage	Type d'outil	Type d'embrayage (détection d'arrêt)	Niveau de puissance de l'outil
		$t_{II}$ [mm]	$T_{rec}$ [Nm]			Vitesse / Embrayage
X-FCM-R NG combiné à S-BT-GR M8/7 SN 6 HL AL	Aluminium	$\geq 5$	8	Calibrated torque wrench		
				X-BT 1/4" - 8 Nm		
				SBT 4-A22	TRC	1 / 7
				SBT 6-22	ESC (SJ)	1 / 7
				SF 4-A22	TRC	1 / 8
				SF 6-A22	ESC (SJ)	1 / 7
				SF 6H-A22	ESC (SJ)	1 / 7
				SFC 22-A	TRC	1 / 5



- Embrayage à friction électronique (ESC) : ESC a 2 détections d'arrêt, un joint souple (SJ) et un joint dur (HJ). La détection du joint dur est activée en cas d'une baisse de la vitesse (arrêt rapide) et peut entraîner un pic de couple.
- Accouplement temporaire (TRC) : le couple réalisable peut changer progressivement en raison de l'usure de l'embrayage.

## 9 INFORMATION DE COMMANDE

### 9.1 N° d'article et description

Désignation	Code d'article	Description
X-FCM-R NG 23/28	2351685	X-FCM-R NG Coupelle de fixation pour caillebotis étroits (acier inoxydable)
X-FCM-R NG 28/33	2279757	
X-FCM-R NG 32/37	2279758	
X-FCM-R NG 38/43	2279759	
X-FCM-R NG 48/53	2279752	
S-BT-GR M8/7 SN 6 HL	2345767	Goujon fileté S-BT-GR HL
S-BT-GR M8/7 SN 6 HL AL	2350548	Goujon fileté S-BT-GR HL AL





Hilti Aktiengesellschaft  
9494 Schaan, Liechtenstein  
P +423-234 2965

[www.facebook.com/hiltigroup](https://www.facebook.com/hiltigroup)  
[www.hilti.group](https://www.hilti.group)